

# SOLEAL

THE UNIVERSAL  
WINDOW



Architect: A.D.H.  
Photography: DR Technal

IMAGINE WHAT'S NEXT

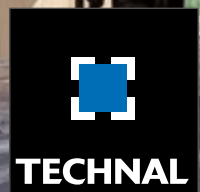



# SOLEAL casement

/ A RANGE OF DIFFERENT SOLUTIONS

## AN ALL-IN-ONE DESIGN

The SOLEAL range offers many possibilities for your projects. SOLEAL is available in two main styles, the visible opening window and the minimal opening window, thus accommodating all your stylistic needs. This range is characterised by the number of options available: 1 & 2 leaf windows and balcony doors, integrated or stacked units, casements on sills, with transom or side light, and tilting, turning, projecting and top-hung casements.

Most of these options are available in two types of module:

- 55 mm with a 20 mm thermal break
- 65 mm with a 30 mm thermal break.

The evolutionary nature of this range means that it will be able to cope with the increasingly demanding regulatory requirements of the future. The balcony doors are also available with disabled access thresholds. The installation and finishing options are the same for both SOLEAL doors and sliding systems.

## A NEW GENERATION OF WINDOWS

The SOLEAL range offers exceptional thermal and acoustic performance, and weather resistance - properties which come as standard with the new generation of TECHNAL windows. As a result, SOLEAL not only meets current regulatory demands but anticipates future requirements with its high performance.



# MINIMAL



MINIMAL

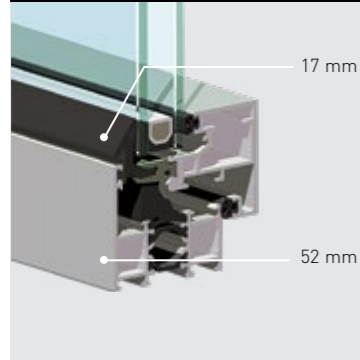

The flashing ensures the seamless integration of the opening frame and the fixed and opening sections appear as one. The fine, minimalist lines are reminiscent of the steel frame construction used for commercial buildings.

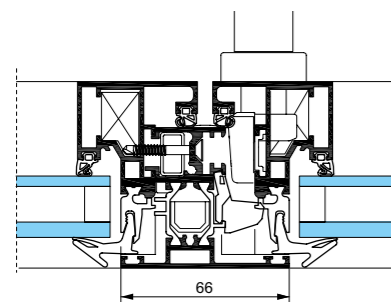

Available in the 55 mm and 65 mm version



EQUILIBRE

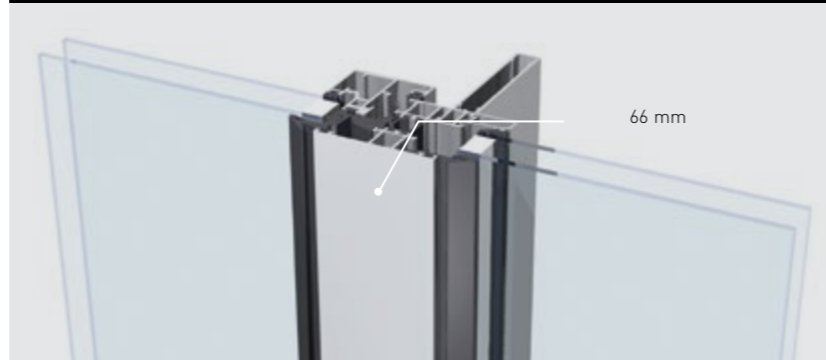

Consistent external appearance for the whole assembly. A harmonious balance between the mullions and transoms. Composite assemblies for large sizes whilst still minimising the external visual impact with a 66-mm aluminium frame.

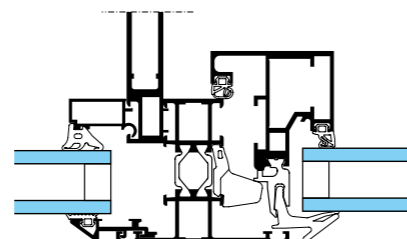

Available in the 55 mm version



CLIP-ON TRIM

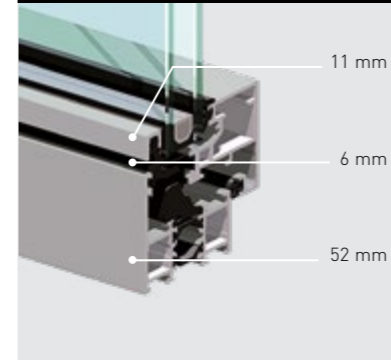

The clip-on trim subtly borders the opening frame, giving it a contemporary feel.

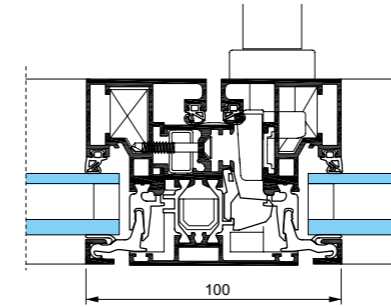

Available in the 55 mm and 65 mm version

# VISIBLE



VISIBLE

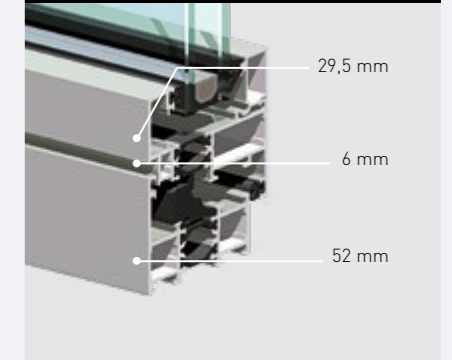

The visual impact of the opening and outer frames has been carefully balanced resulting in an assembly purveying opulence and high quality.

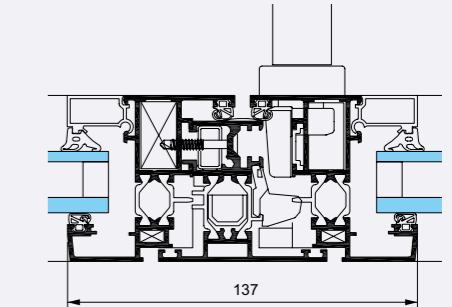

Available in the 55 mm and 65 mm version

# SOLEAL

/ THE UNIVERSAL WINDOW

SOLEAL MINIMAL  
EN 55 MM



SOLEAL VISIBLE  
EN 65 MM



## KEY FEATURES AND INNOVATIONS

### DESIGN

- Several versions are available to meet all your projects' requirements:
- Minimal: a minimalist opening frame with fine and subtle lines
- Equilibre: a minimalist version which emphasises the symmetry and finesse of the assemblies
- A minimalist opening frame with "clip-on trim" creating a contemporary feel
- A visible opening assembly purveying opulence and high quality
- Concealed drainage for discrete water removal from all configurations of opening as well as fixed frames
- Flashings available in different shapes and styles

### MULTIPLES CONFIGURATIONS

- Fixed casement
- 1 and 2 leaf
- Integrated or stacked composite assemblies with transom or side lights
- Projecting top-hung casement

### THERMAL, WEATHER RESISTANCE AND ACOUSTIC PERFORMANCE

- SOLEAL casement frames meet the demands of regulatory changes: RT2012, permeability criteria for Low Energy Consumption Buildings and acoustic attenuation requirements in urban areas

### CLOSURE SYSTEMS AND SECURITY

- Various combinations are available up to 6-point with or without key locking systems
- Handles centred on the central mullions of 2-leaf casements reduced to 66 mm (minimal opening frame) and 116 mm (visible opening frame) are available as an option
- The Technal-exclusive handles are available for all configurations and ensure style consistency regardless of the type of opening system and can be adapted for use on doors and sliding systems
- Windows subjected to forced entry delay tests achieving a score of RC2 in accordance with the EN-1627-30 standard.

### ACCESSIBILITY

- System adapted for easy access for all available configurations

### INNOVATION

- 7 patents for innovative window vision
- 3 patents pending for aesthetic ideals

# SOLEAL / MADE-TO-MEASURE DESIGN

PURETY, FINESSE AND SUBTLETY



Minimal version



Clip-On Trim  
Minimal version



Visible version

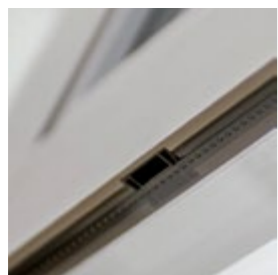

Concealed drainage



Subtle edges

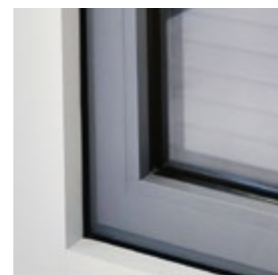

Concealed hardware

A WIDE RANGE OF CLOSURE SYSTEMS



Stainless steel  
handle



Exclusive Technal-designed  
handle



Exclusive Technal-designed  
handle with lock

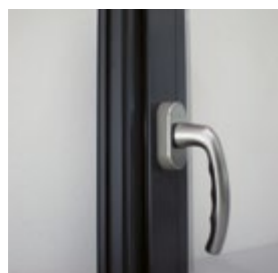

Classic handle

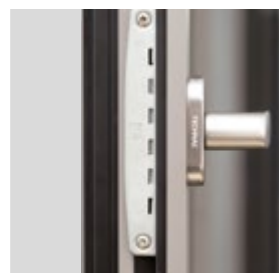

Closure systems  
operated via 2-way  
espagnolette locking  
and drive



Architects: Ateliers Jean NOUVEL / François Fontès Architecture  
Photography: Luc Boegly



## SOLEAL / FOR DISABLED USERS

The disabled access thresholds used on SOLEAL balcony doors meet the requirements of the French regulations for door and balcony door access whilst ensuring optimum weather tightness



Disabled access threshold with thermal break

## SECURITY

- Windows can be fitted with 2 to 6 point locks depending on the desired level of security.
- Windows have been subjected to forced entry delay tests achieving a score of RC2 in accordance with the EN-1627-30 standard.



Top point



Mid-point between the handle and mechanism



Bottom of opening frame



Bottom of outer frame

# SOLEAL CASEMENT FRAME 55

/ ADAPTABILITY AND DIVERSITY

## WIDE RANGE

Several models are offered to meet all stylistic requirements:

- "Contemporary" for residential or commercial architectural projects
- "Classic" for projects involving the general public
- "Traditional" to provide an exact replacement for the original joinery used on traditional buildings
- The installation and covering conditions are the same for both SOLEAL doors and sliding systems

## MULTIPLE CONFIGURATIONS

- Fixed casement
- 1 and 2 leaf
- Integrated or stacked composite assemblies with transom or side lights
- Projecting and top-hung casement

## 2 VERSIONS OF OPENING FRAMES

- Minimal and Clip-on trim versions opening frame with glazing infills up to 32 mm
- Visible opening frame with glazing infills up to 42 mm
- The fixed sections shared by both types of opening frames can accommodate glazing up to 42 mm

## THERMAL, WEATHER RESISTANCE AND ACOUSTIC PERFORMANCE

- Optimised thermal loss values  $U_w$  up to  $1.2 \text{ W/m}^2 \cdot \text{°K}$ ,  $S_w = 0.41$  and  $LT_w = 0.54$  with triple glazing ( $U_g = 0.6 + \text{warm edge}$ )
- Very low air permeability meeting 2012 thermal regulations Q4 up to  $0.058 \text{ m}^3/(\text{h} \cdot \text{m}^2)$
- Very good thermal performance: up to 40 dB (RA, Tr) of acoustic attenuation. Test on window with 44.1/20/12 glazing

### CONTEMPORARY MODEL



Straight and minimalist



For architectural projects

### CLASSIC MODEL



Soft and rounded



For residential projects

### TRADITIONAL MODEL



Bevelled and moulded



For traditional buildings

	VISIBLE	CLIP-ON TRIM	MINIMAL	EQUILIBRE
Contemporary	x	x	x	x
Classic	x	x	x	
Traditional	x	x	x	





# CROSS-SECTIONS

## SOLEAL 55 MINIMAL

### 1 AND 2 LEAF WINDOW AND BALCONY DOOR

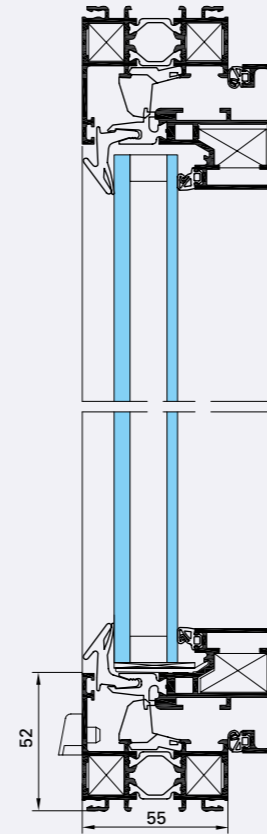
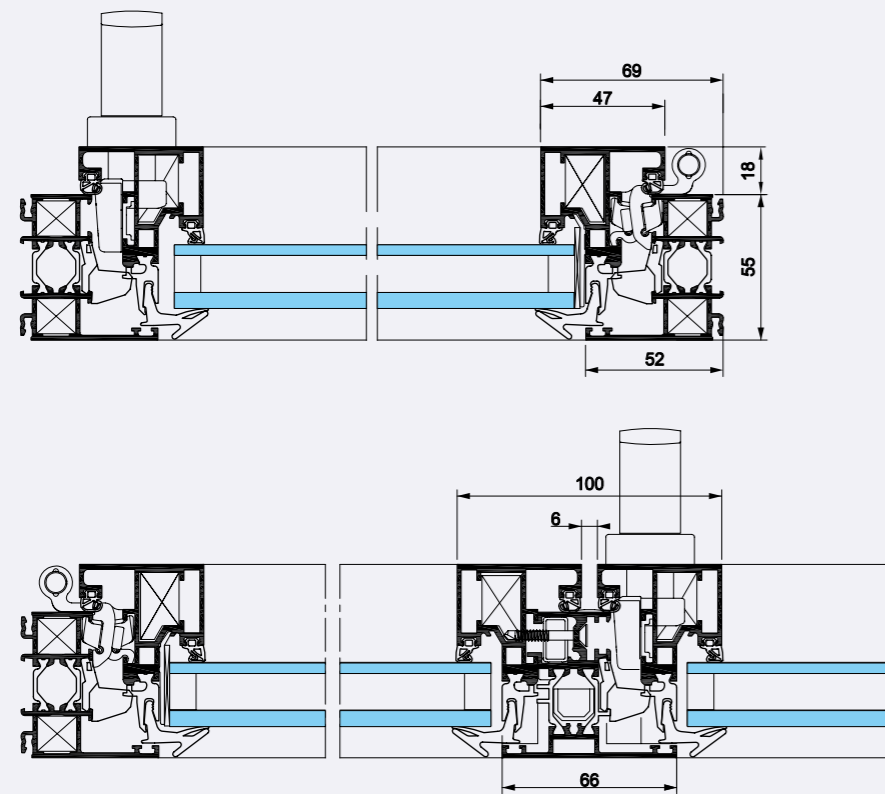

### CENTRED HANDLE OPTION

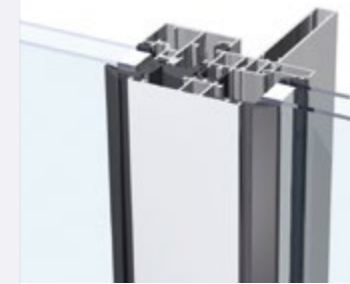
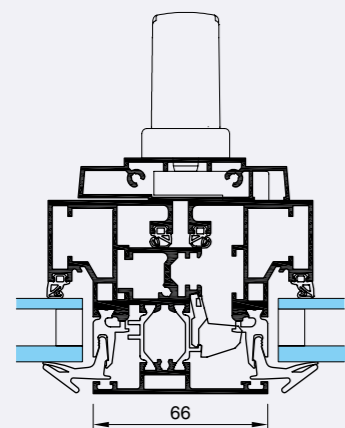

## SOLEAL 55 MINIMAL EQUILIBRE VERSION

- The "Equilibre" version offers symmetry between the external appearance of all configurations of 66 mm assemblies.
- The integration of minimal opening frames is characterised by fine and simple lines.
- The various internal reinforcement solutions, 95 or 120 mm, vertical or horizontal, means that the facades can incorporate floor to ceiling designs (3 m).
- The drainage systems, which are fully integrated into the transoms, provide a smooth and flat external appearance.

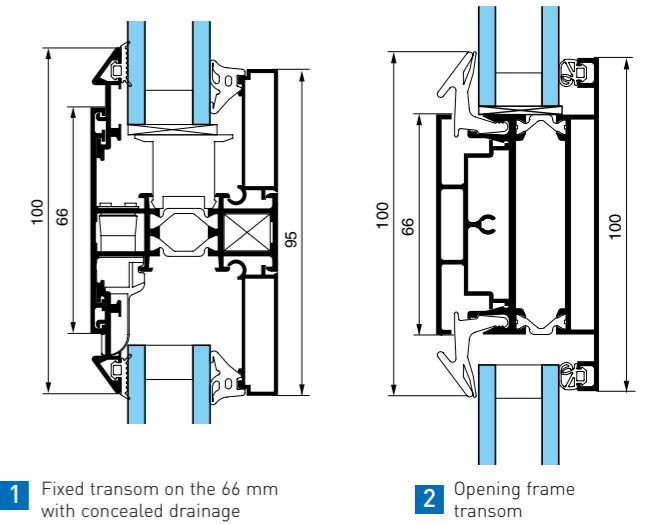

**1** Fixed transom on the 66 mm with concealed drainage

**2** Opening frame transom

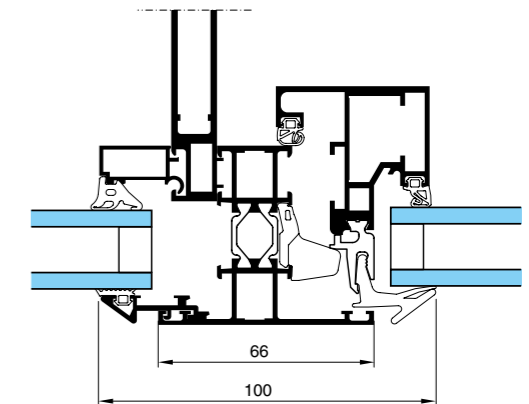

**3** Flat external appearance of the mullion on the 66 mm with aluminium reinforcement

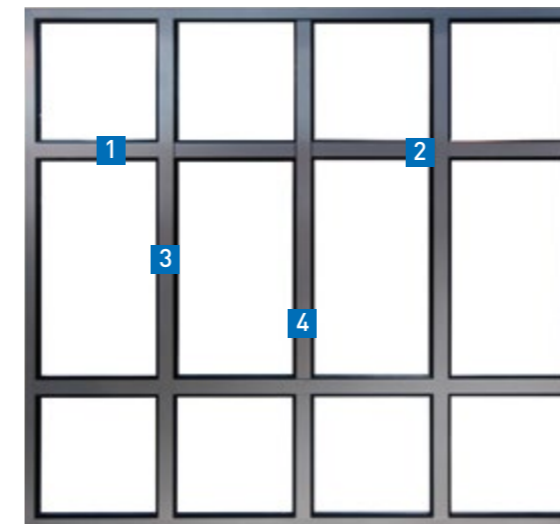

Composite frame with double leaf open-in on fixed cill with 4 lateral sections

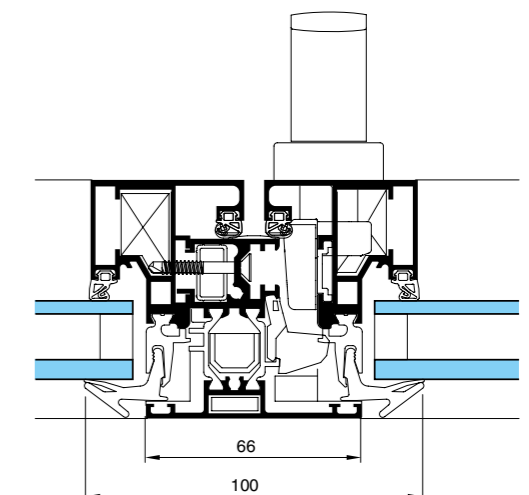

**4** Subtlety of the opening vent's central mullion 2 leaves = 66 mm



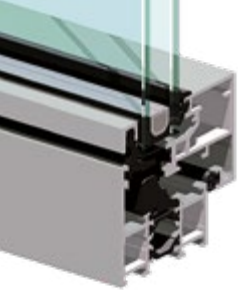

# CROSS-SECTIONS

SOLEAL 55 MINIMAL  
CLIP-ON TRIM VERSION

1 AND 2 LEAF WINDOW AND BALCONY DOOR

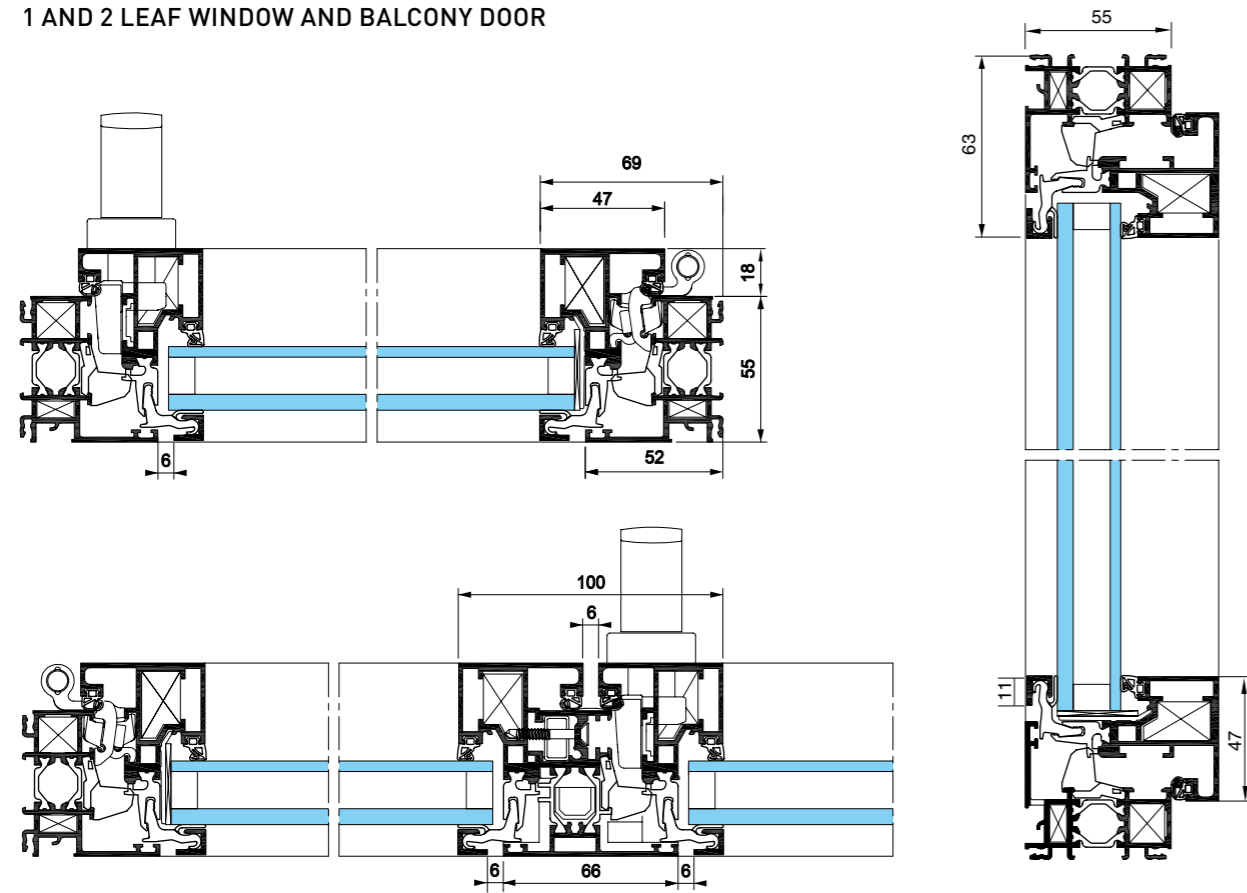

INTEGRATION INTO GEODE CURTAIN WALLING

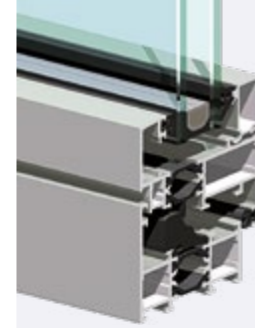
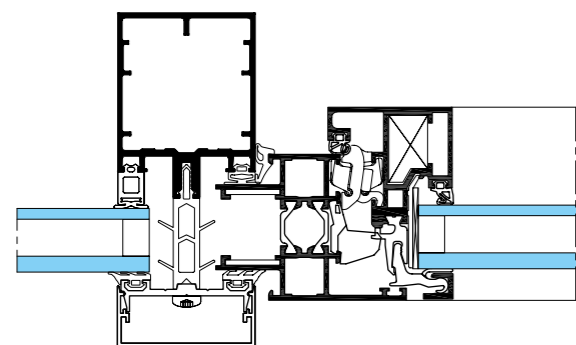

SOLEAL 55 VISIBLE

1 AND 2 LEAF WINDOW AND BALCONY DOOR

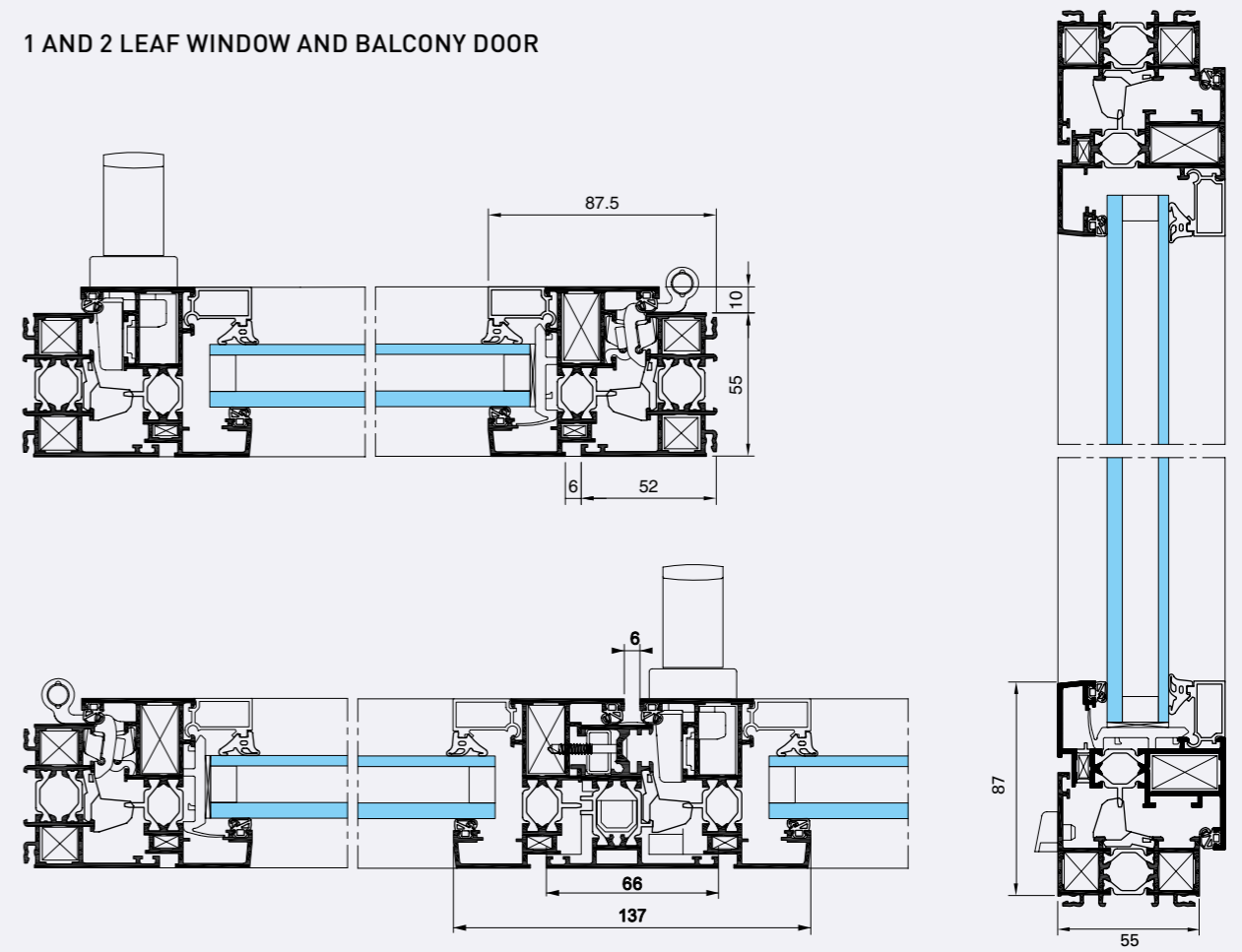

CENTRED HANDLE OPTION

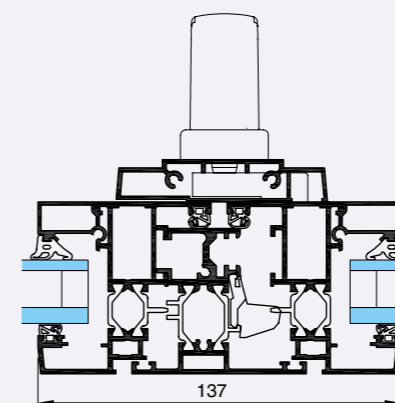

# SOLEAL CASEMENT FRAME 65

/ ADVANCED PERFORMANCE

## THERMAL AND WEATHER RESISTANCE PERFORMANCE

- Optimised thermal loss values up to  $0.9 \text{ W/}^2\cdot^{\circ}\text{K}$ ,  $\text{Sw} = 0.41$  and  $\text{LTw} = 0.54$  with triple glazing ( $\text{Ug} = 0.5 + \text{warm edge}$ )
- Very low air permeability meeting 2012 thermal regulations Q4 up to  $0.02 \text{ m}^3/(\text{h}\cdot\text{m}^2)$

## ACOUSTIC PERFORMANCE SUITED TO URBAN ENVIRONMENTS

- Very good sound-proofing: up to 43 dB (RA, Tr) of acoustic attenuation
- Test on window with 88.1/-20/-66.2 sound-proof glazing

## 2 VERSIONS OF OPENING FRAMES

- To meet all market needs, many of the configurations of the SOLEAL 65 range are available in opening and open-out versions
- Minimal open-in frame glazing infill up to 42 mm
- Visible opening frame (open-in and open-out) glazing infill up to 52 mm
- The fixed sections shared by both types of opening frames can accommodate glazing up to 52 mm

## CONCEALED HARDWARES ON VISIBLE OPENING FRAME

- Available with  $110^{\circ}$  opening and maximum weight: 160 kg
- Offers a variety of frames: 1 leaf, 2 leaves, French, tilt & turn opening frames

## MULTIPLE CONFIGURATIONS

- Fixed casement
- 1 and 2 leaf
- Integrated or stacked composite assemblies with transom or side lights

## SPECIAL OPENINGS

- Top-hung casement
- Projecting casement
- Parallel casement
- Horizontal and vertical pivot casement
- Turn/slide casement

# CROSS-SECTIONS

## SOLEAL 65 MINIMAL OPEN-IN

### 1 AND 2 LEAF WINDOW AND BALCONY DOOR

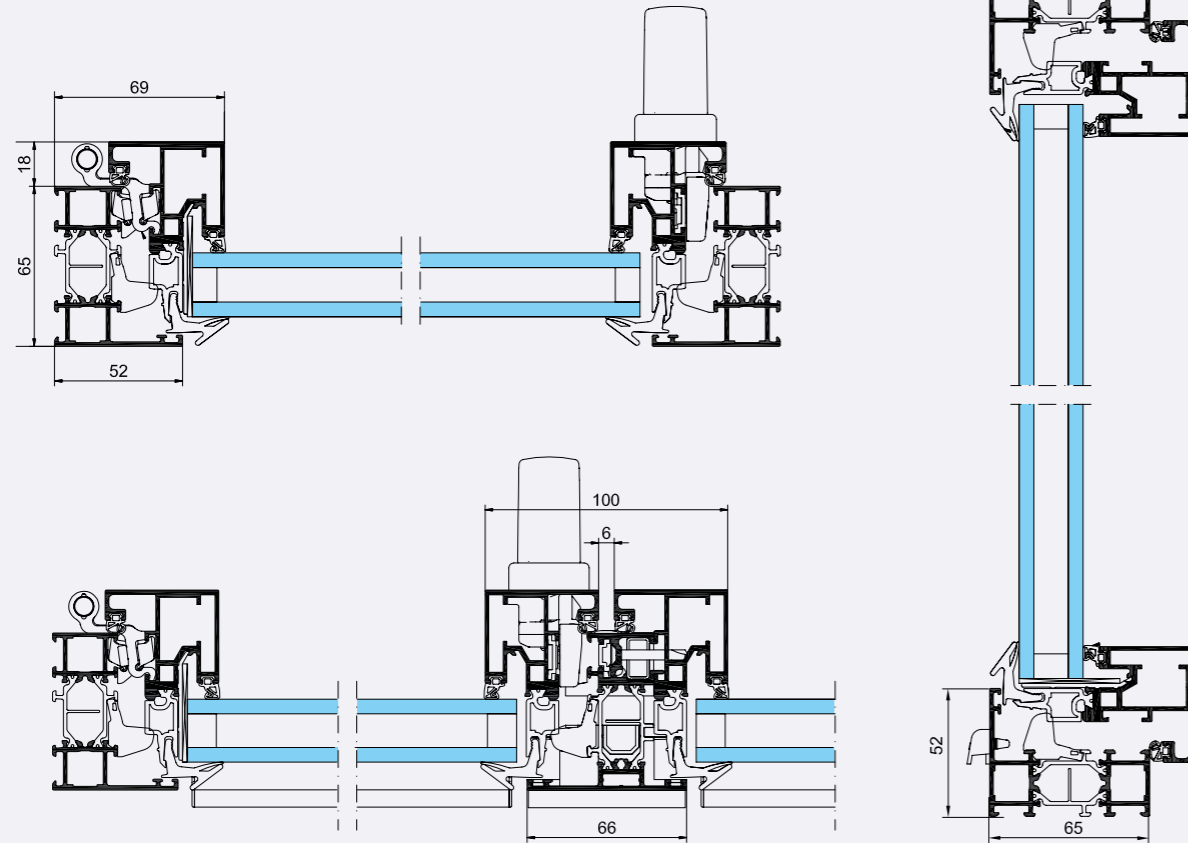

### INTEGRATION INTO GEODE CURTAIN WALLING OPEN-IN AND OPEN-OUT

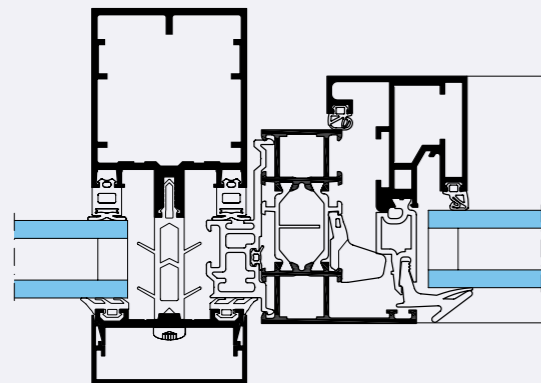

## SOLEAL 65 VISIBLE OPEN-IN

### 1 AND 2 LEAF WINDOW AND BALCONY DOOR

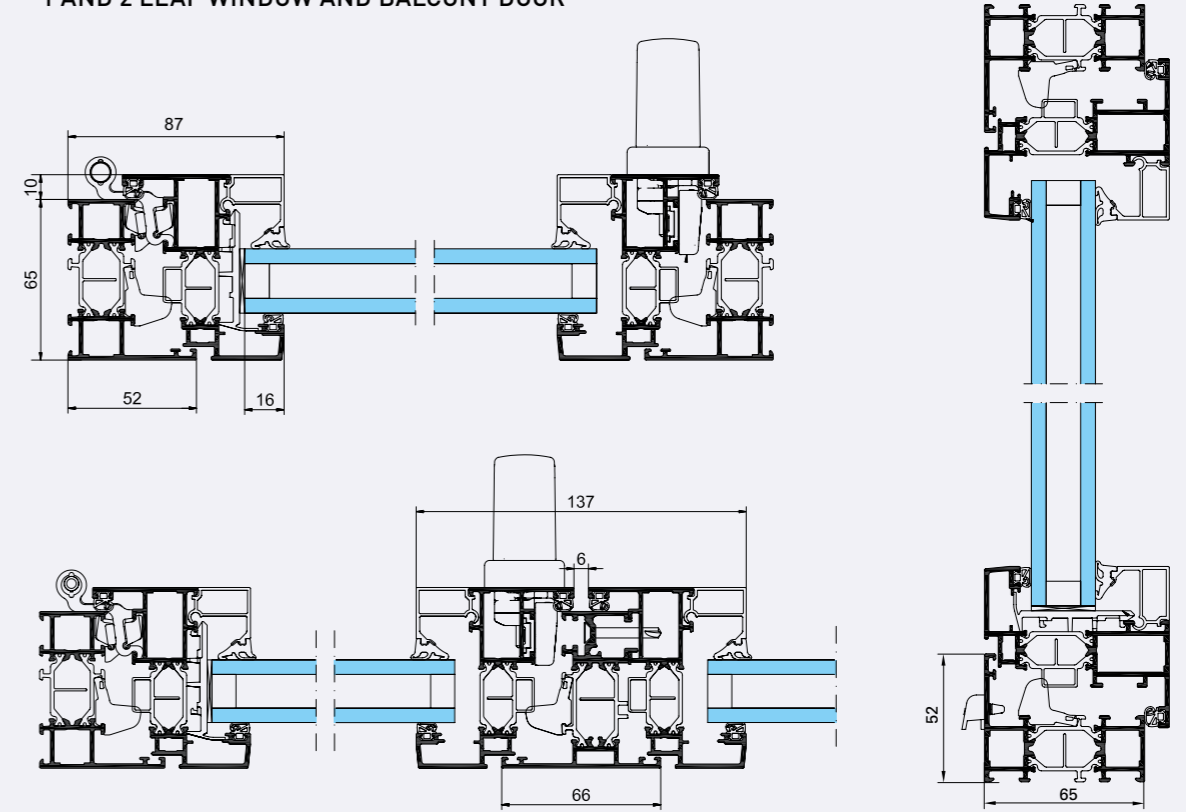

### CONCEALED HARDWARES

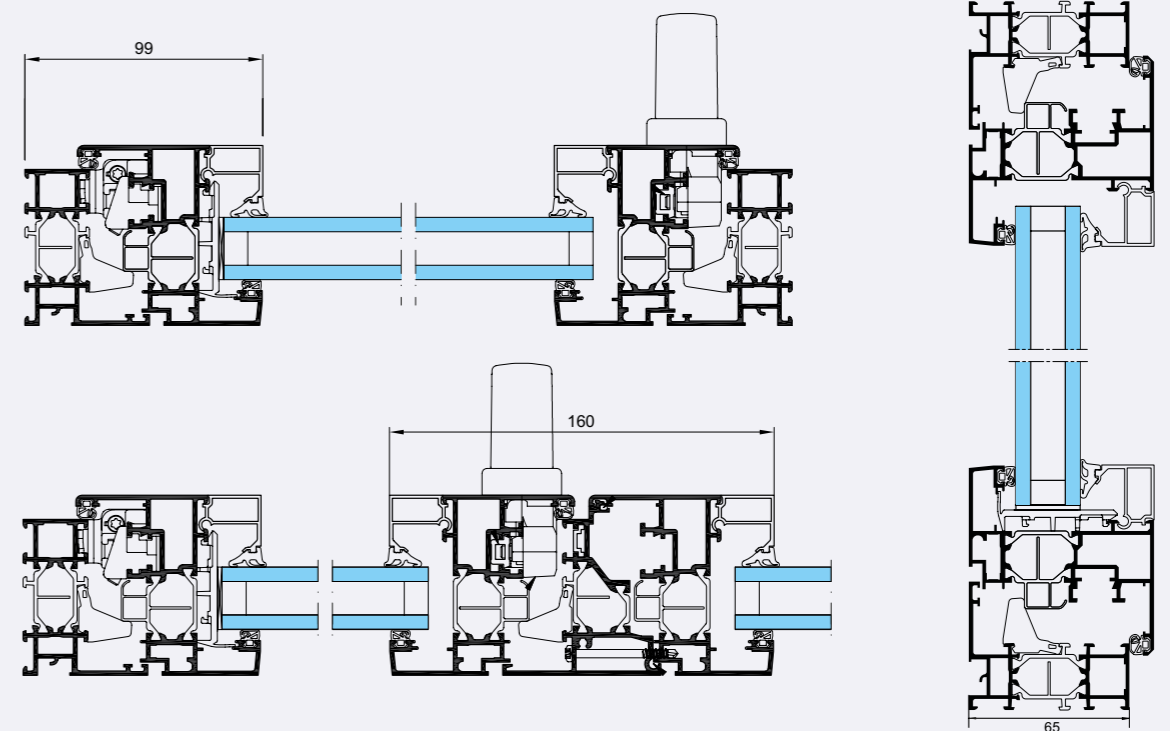

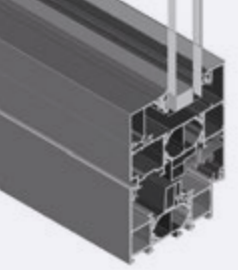

**SOLEAL 65 VISIBLE  
OPEN-OUT**

**1 AND 2 LEAF WINDOW AND BALCONY DOOR**

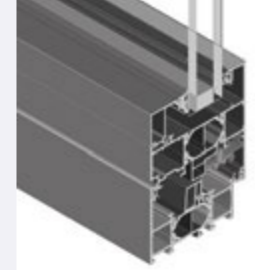
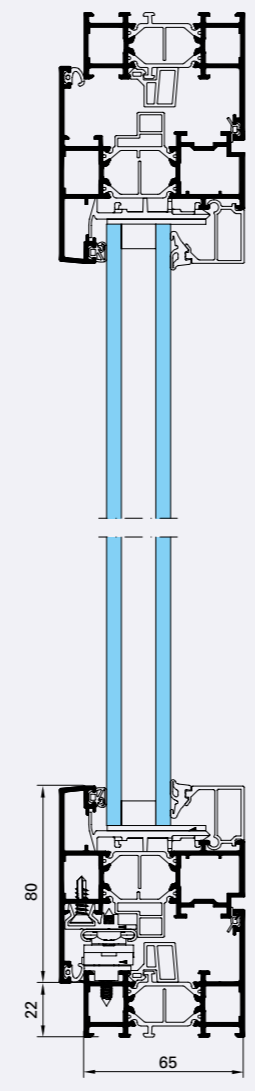
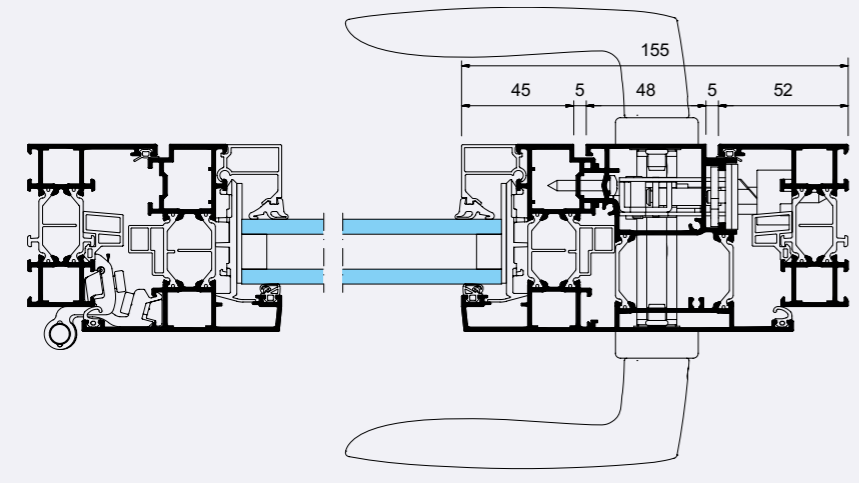
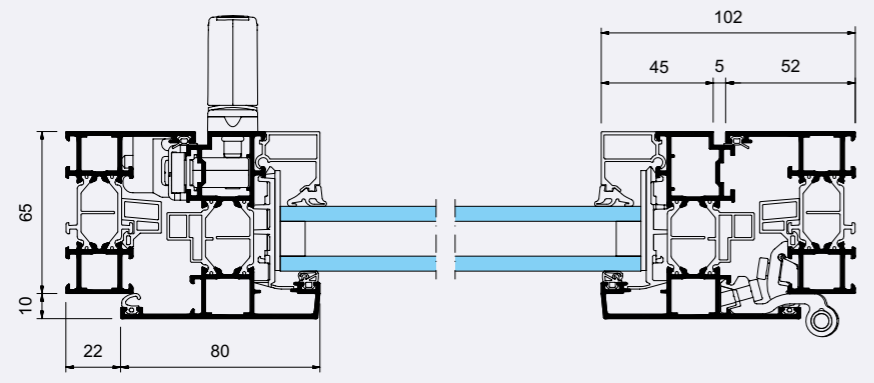

**SOLEAL 65 VISIBLE**

**TILT/TURN CASEMENT**

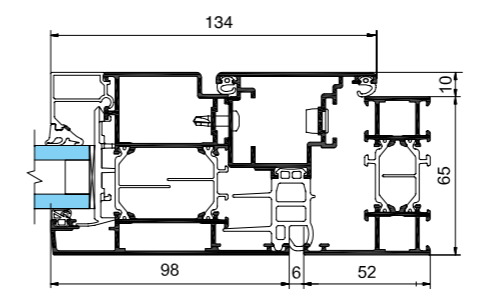

**2-LEAF BALCONY DOOR WITH DISABLED  
ACCESS THRESHOLD  
OPEN-IN**

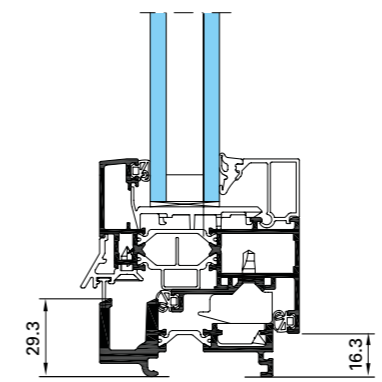

**TOP-HUNG CASEMENT  
OPEN-OUT**

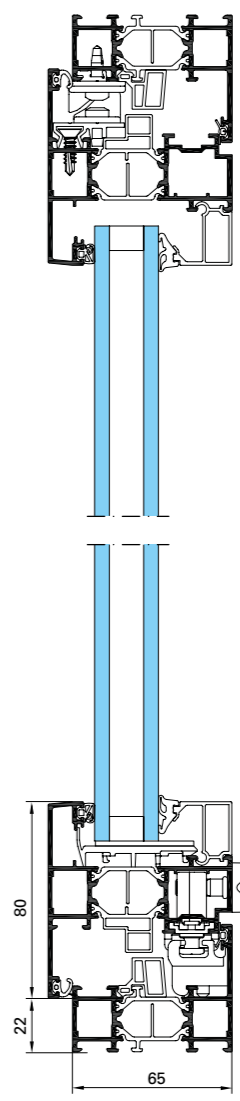

# CONFIGURATIONS

All configurations feature concealed drainage.  
All balcony door configurations are available with disabled access thresholds

## EXTERNAL VIEW DIAGRAMS

### OPEN-IN

\* 55 and 65 mm version



casement fixed\*

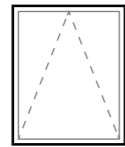

casement bottom-hung\*

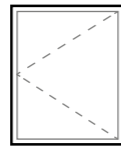

1 leaf\*

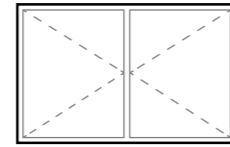

2 leaves\*

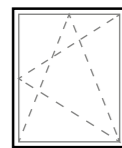

Turn/tilt or tilt/turn 1 leaf\*

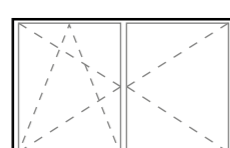

Turn/tilt or tilt/turn 2 leaves\*

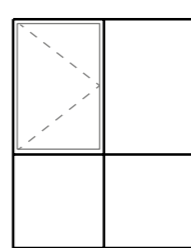

Fixed composite open-in window\*

### SPECIAL OPENINGS

\*\* 65 mm version

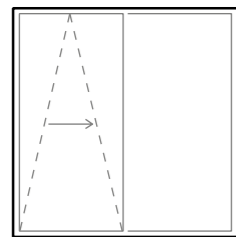

Turn/tilt\*\*

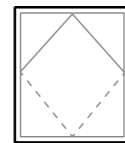

Tilting\*\*



Turning\*\*

### OPEN-OUT

\* 55 and 65 mm version

\*\* 65 mm version

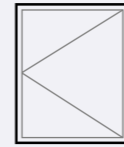

1 vantail\*\*

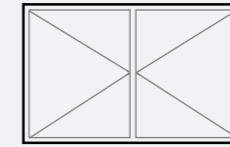

2 leaves\*\*

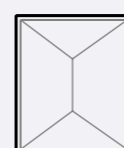

Parallel window\*\*



Projecting window\*



Top-hung window\*

# SOLEAL CASEMENT

/ INSTALLATION CASES (SAME FOR 55 AND 65 MM)

INSTALLATION INTO EXTERNAL CLADDING

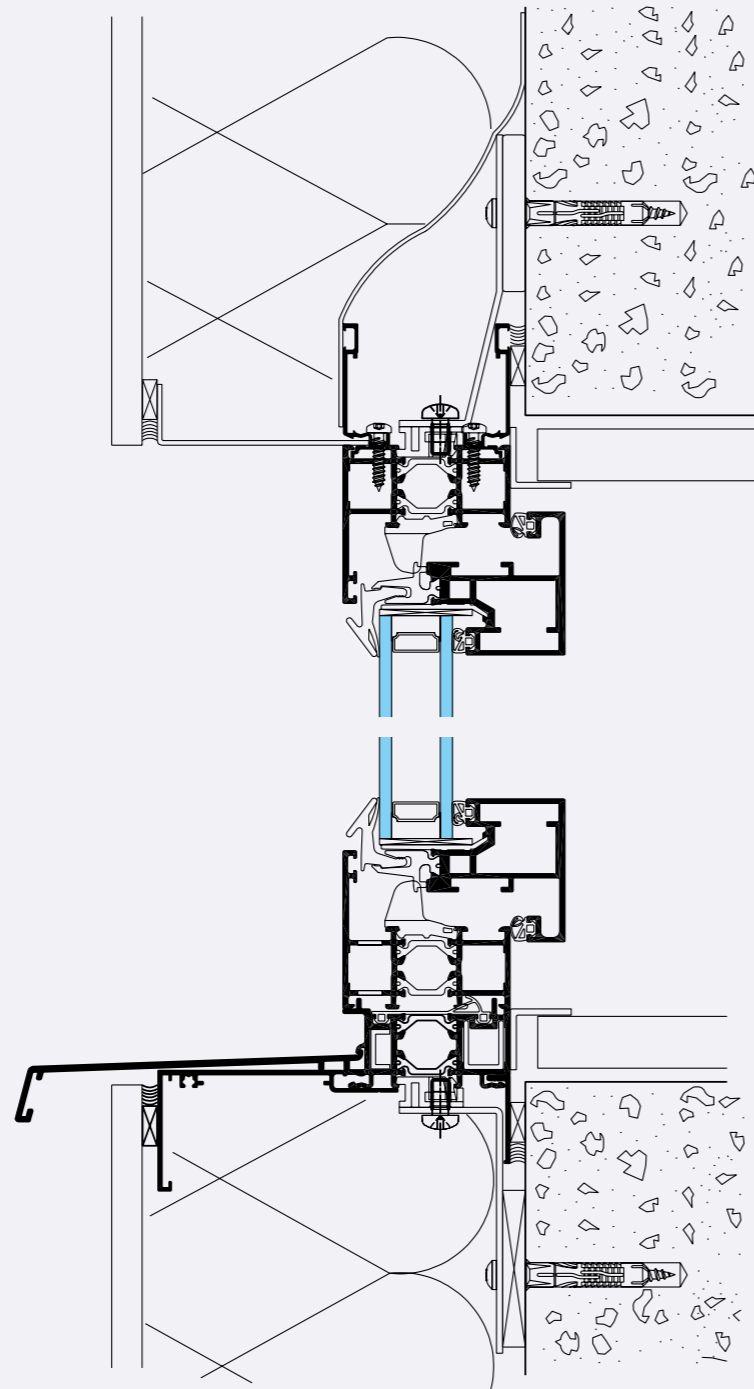

INTERNAL INSTALLATION

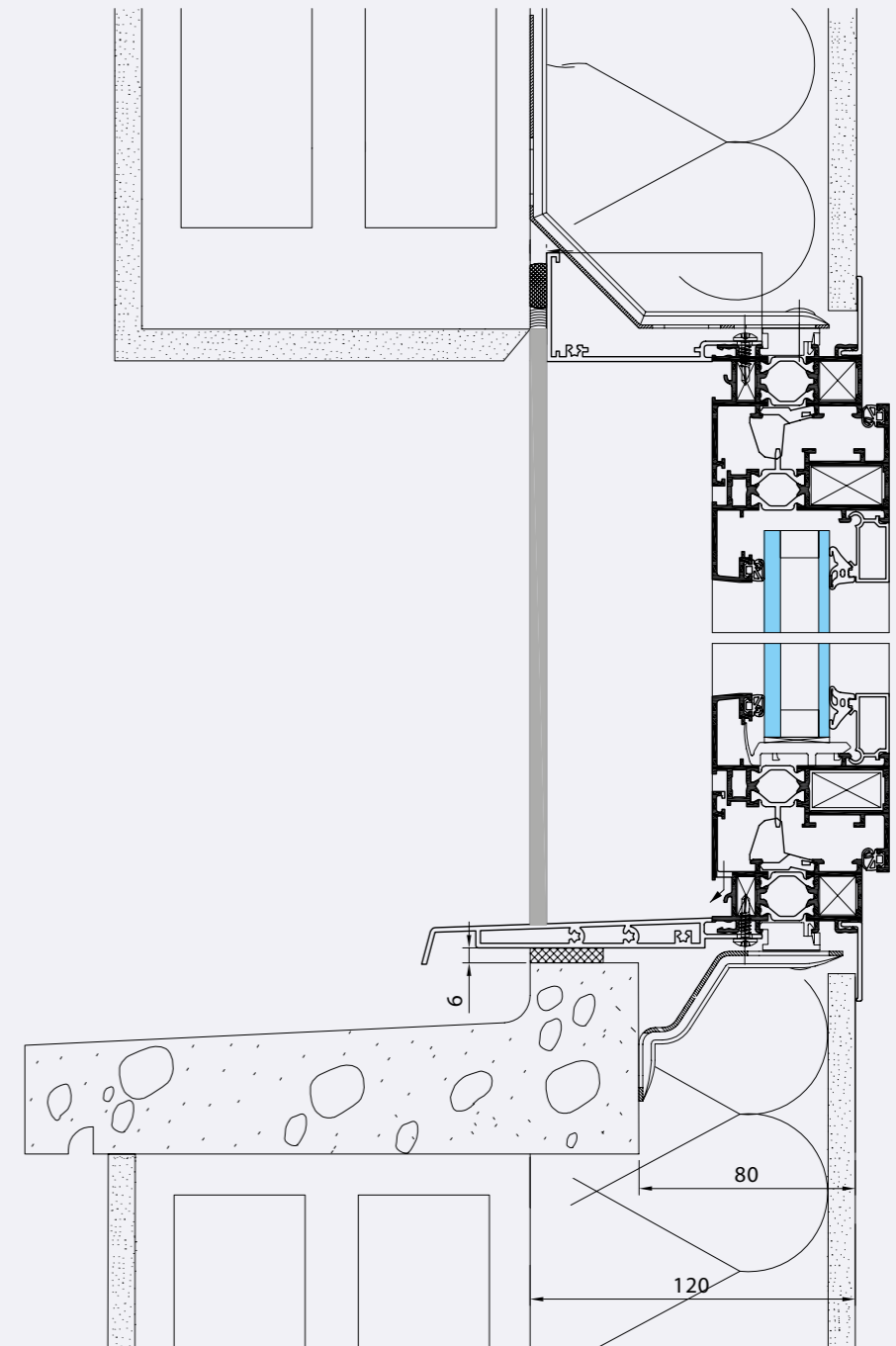

# SOLEAL CASEMENT FRAME

/ INSTALLATION CASES (SAME FOR 55 AND 65 MM)

INSTALLATION FOR RENOVATION

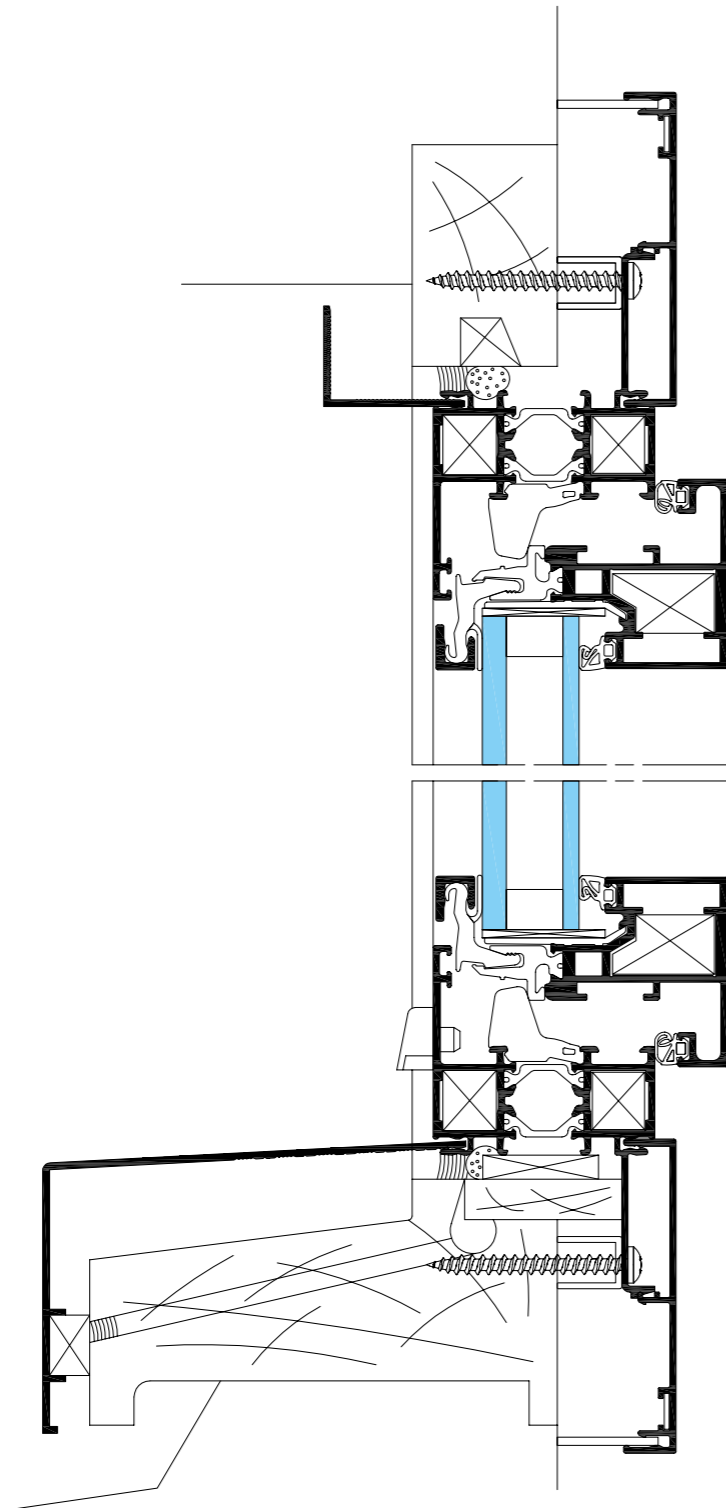

Architects: Tajllander Architectes Associés  
Photography: DR Technat

# SOLEAL CASEMENT FRAME 55

## / PERFORMANCE

Whether for residential or commercial buildings, the RT 2012 aims to limit the maximum energy consumption of new buildings.

Therefore, SOLEAL windows contribute to maintaining the permeability of the building's outer shell thanks to very good Q4 ratings.

There are no minimum requirements in terms of frames but Technal has been assisting architects with these new demands.

WEATHER TIGHTNESS A.E.V. (Air, Water, Wind)						
Configurations	Size W x H in m	A	W	Wi	Q4	Q100
<b>Soleal Minimal</b>						
<b>Window</b>						
1 leaf Turn/tilt	1,6 x 1,8	4	9A	C3	0	0
<b>Balcony door</b>						
1 leaf	1,26 x 2,28	4	9A	C3	0,5	1,27
2 leaves with disabled access threshold	1,4 x 2,25	4	8A	C3	0,12	0,36
<b>Soleal Visible</b>						
<b>Window</b>						
1 leaf Turn/tilt	1,4 x 1,6	4	9A	C3	0	0
<b>Balcony door</b>						
1 leaf split-hinge 3 blades	1,2 x 2,25	4	9A	C3	0	0

WEATHER TIGHTNESS (Air, Water, Wind)	Equivalence	
	Q4	Q100*
Individual housing unit m <sup>3</sup> (h.m <sup>2</sup> )	0,6	5,1
Collective housing unit m <sup>3</sup> (h.m <sup>2</sup> )	1	8,5

\*Q100 represents the casement leak at 100 pascals. For Low Energy Consumption Buildings, the Q100 must not exceed 5.1 for individual housing units and 8.5 for collective housing units (m<sup>3</sup>/h.m<sup>2</sup>).

ACOUSTIC PERFORMANCE								
Configurations	Designation	Size W x H in m	Glazing			Window		
			Rw [C; Ctr]	Ra	Ra,Tr	Rw [C; Ctr]	Ra	Ra,Tr
<b>SOLEAL Minimal and Visible</b>								
<b>Window</b>								
1-leaf MOF turn/tilt	6(16) 4	1,45 x 1,48	34	33	29	34	33	31
1-leaf MOF turn/tilt	64-1SI(12) 10	1,45 x 1,48	42	40	37	42	41	38
1-leaf MOF turn/tilt	6(16) 4	1,45 x 1,48	34	33	29	35	34	31
1-leaf MOF turn/tilt	44-1SI(20) 12	1,45 x 1,48	46	44	40	43	43	40
1-leaf MOF turn/tilt	12(12)8	1,23 x 1,48	38	37	35	37	36	35
<b>Balcony door</b>								
2- leaf VOF	6(16) 4	1,45 x 2,18	34	33	29	36	35	32

According to EN 14351-1 for windows, this performance data is valid for:  
 - Rw + Ctr glazing (for the Ra,Tr rating) equal to or greater than the values of the tested glazing- corrections  
 - 1 dB for leaf surface area of + 50% to + 100% / - 2 dB for + 100 % to + 150% / - 3 dB for + 150 % to + 200%

MOF = Minimal Opening Frame

VOF = Visible Opening Frame



# SOLEAL CASEMENT FRAME 55

## / PERFORMANCE

THERMAL PERFORMANCE					
	Size W x H in m		With Ug = 1,1 + Warm edge	With Ug = 1,0 + Warm edge	With Ug = 0,8 + Warm edge
Soleal Minimal					
<b>Window</b>					
1 leaf	1,25 x 1,48	Uw (W/m².K)	1,5	1,5	1,3
		Sw	0,52	0,42	0,42
		TLw	0,64	0,57	0,57
2 leaves	1,53 x 1,48	Uw (W/m².K)	1,6	1,6	1,4
		Sw	0,50	0,40	0,40
		TLw	0,61	0,54	0,54
<b>Balcony door</b>					
1 leaf	1,25 x 2,18	Uw (W/m².K)	1,5	1,4	1,2
		Sw	0,54	0,43	0,43
		TLw	0,67	0,59	0,59
2 leaves	1,53 x 2,18	Uw (W/m².K)	1,6	1,5	1,3
		Sw	0,51	0,41	0,41
		TLw	0,63	0,56	0,56
Soleal Minimal - Clip-on trim					
<b>Window</b>					
1 leaf	1,25 x 1,48	Uw (W/m².K)	1,6	1,5	1,3
		Sw	0,52	0,41	0,41
		TLw	0,65	0,57	0,57
2 leaves	1,53 x 1,48	Uw (W/m².K)	1,7	1,6	1,5
		Sw	0,49	0,39	0,39
		TLw	0,61	0,54	0,54
<b>Balcony door</b>					
1 leaf	1,25 x 1,48	Uw (W/m².K)	1,5	1,4	1,3
		Sw	0,53	0,42	0,42
		TLw	0,67	0,59	0,59
2 leaves	1,53 x 1,48	Uw (W/m².K)	1,6	1,5	1,4
		Sw	0,51	0,41	0,41
		TLw	0,63	0,56	0,56
<b>Balcony door with disabled access threshold</b>					
1 leaf	1,25 x 2,18	Uw (W/m².K)	1,5	1,5	1,3
		Sw	0,54	0,43	0,43
		TLw	0,67	0,6	0,6
2 leaves	1,53 x 2,18	Uw (W/m².K)	1,6	1,6	1,4
		Sw	0,51	0,41	0,41
		TLw	0,63	0,57	0,57

Uw: Frame thermal loss / Sw: Solar factor / TLw: Light transmission

THERMAL PERFORMANCE*						
	Size W x H in m		With Ug = 1,1 + Warm edge	With Ug = 1,0 + Warm edge	With Ug = 0,8 + Warm edge	With Ug = 0,6 + Warm edge
Soleal Visible - Open-in						
<b>Window</b>						
1 leaf	1,25 x 1,48	Uw (W/m².K)	1,6	1,5	1,4	1,2
		Sw	0,49	0,39	0,39	0,39
		TLw	0,61	0,54	0,54	0,54
2 leaves	1,53 x 1,48	Uw (W/m².K)	1,7	1,6	1,4	1,3
		Sw	0,46	0,37	0,37	0,37
		TLw	0,56	0,5	0,5	0,5
<b>Balcony door</b>						
1 leaf	1,25 x 2,18	Uw (W/m².K)	1,5	1,4	1,3	1,1
		Sw	0,51	0,43	0,43	0,43
		TLw	0,63	0,56	0,56	0,56
2 leaves	1,53 x 2,18	Uw (W/m².K)	1,6	1,5	1,4	1,2
		Sw	0,48	0,4	0,4	0,4
		TLw	0,58	0,52	0,52	0,52
Soleal Visible - Open-out						
Top hung window	1,53 x 1,48	Uw (W/m².K)	1,7	1,6	1,5	1,3
		Sw	0,46	0,37	0,36	0,36
		TLw	0,56	0,5	0,5	0,5
Projection window with central gasket	1,53 x 1,48	Uw (W/m².K)	1,5	1,5	1,3	1,2
		Sw	0,46	0,36	0,36	0,36
		TLw	0,56	0,5	0,5	0,5

\* Thermal performance data obtained with addition insulation at the bottom of the glazing rebate

# SOLEAL CASEMENT FRAME 65

## / PERFORMANCE

WEATHER TIGHTNESS A.E.V. (AIR, WATER, WIND)						
Frame under ITT (Initial Type Test)						
Configurations	Size W x H in m		Report n°	Q4	Q100	
	H x W	Classification				
<b>Special Openings</b>						
Tilting (visible pivot)	1,7 x 2	A3 E8A VC4	404/12/276-4 FCBA	0,41	3,54	
Turning (concealed pivot)	2,2 x 1,8	A4 E6A VC4	404/12/413-5 FCBA	0,08	0,72	
<b>Visible Open-in Frame</b>						
<b>Window</b>						
1 leaf Tilt/Turn	1,6 x 1,2	A4 E1050 VC4	404/12/111-1 FCBA	0,06	0,52	
1 leaf Tilt/Turn	1,6 x 1,2	A4 E1050 VC5	404/11/231-2 FCBA	0,06	0,53	
<b>Balcony door</b>						
2-leaf balcony doors	2,25 x 1,6	A4 E9A VC2	404/11/231-1 FCBA	0,28	2,4	
1-leaf balcony door with side light	2,25 x 2	A4 E9A VB3	404/11/461-3 FCBA	0,08	0,65	
<b>Minimal Open-in Frame</b>						
1-Leaf Tilt/Turn Window	1,6 x 1,2	A4 E750 VC4	404/12/111-2 FCBA	0,03	0,28	
1-leaf balcony door with side light	2,25 x 2	A4 E9A VB3	404/12/461-1 FCBA	0,02	0,15	
<b>Visible Open-out Frame</b>						
Top-hung assembly (opening frame's dimensions)	1,5 x 1,4	A4 E1050 VC4	404/12/276-3 FCBA	0,02	0,19	
Projection	1,8 x 1,6	A3 E1050 VC4	404/12/276-1 FCBA	0,07	0,58	
<b>Visible opening - Concealed hardware</b>						
1-Leaf Tilt/Turn Window	1,8 x 1,3	A4 E1200 VC4	404/14/29-1 FCBA	0,063	0,54	
1-leaf balcony door with side light	2,5 x 1,4	A4 E1200 VC4	404/14/29-3 FCBA	0,015	0,13	

Uw: Frame thermal loss / Sw: Solar factor / LTW: Light transmission

ACOUSTIC PERFORMANCE								
Frame size W x H (1480 x 1230)								
Configurations	Glazing	Seal AS0180	Glazing performance alone			Window performance		
			RW (C; Ctr)	RA	RA,tr	RW (C; Ctr)	RA	RA,tr
<b>Soleal Visible</b>								
1-leaf turn/tilt VOF	6-16-10		37	36	34	38 [-2;-3]	36	35
1-leaf turn/tilt VOF	44.1 sil-16-12	x	46	44	40	44 [-2;-5]	42	39
Turn/tilt VOF	88.1-20-66.2	x	54	53	49	46 [-1;-3]	45	43
<b>Soleal Minimal</b>								
1-leaf turn/tilt MOF	6-16-10		37	36	34	37 [-1;-3]	36	34

MOF = Minimal Opening Frame / VOF = Visible Opening Frame

THERMAL PERFORMANCE							
Soleal Visible							
Open-in configurations	Size W x H in m		With Ug = 1,1 + Warm edge	With Ug = 1,0 + Warm edge	With Ug = 0,8 + Warm edge	With Ug = 0,6 + Warm edge	With Ug = 0,5 + Warm edge
			Glazing 24 mm	Glazing 24 mm	Glazing 32 mm	Glazing 42 mm	Glazing 48 mm
			SW-V	SW-V	SW-V	SW-V	SW-V
<b>Window</b>							
1 leaf	1,25 x 1,48	Uw (W/m².K)	1,4	1,3	1,1	1,0	0,9
		Sw	0,48	0,39	0,41	0,41	0,41
		TLw	0,61	0,54	0,54	0,54	0,54
2 leaves	1,53 x 1,48	Uw (W/m².K)	1,5	1,4	1,2	1,1	1,0
		Sw	0,45	0,36	0,38	0,38	0,38
		TLw	0,56	0,50	0,50	0,50	0,50
<b>Balcony door</b>							
1 leaf	1,25 x 2,18	Uw (W/m².K)	1,4	1,3	1,1	0,9	0,9
		Sw	0,50	0,40	0,42	0,42	0,42
		TLw	0,63	0,56	0,56	0,56	0,56
2 leaves	1,53 x 2,18	Uw (W/m².K)	1,4	1,4	1,2	1,0	1,0
		Sw	0,47	0,37	0,39	0,39	0,39
		TLw	0,59	0,52	0,52	0,52	0,52
<b>Special Opening Configurations</b>							
Tilting/turning	1,53 x 1,48	Uw (W/m².K)	1,7	1,6	1,4	1,3	1,2
		Sw	0,42	0,34	0,35	0,35	0,35
		TLw	0,5	0,45	0,45	0,45	0,45

THERMAL PERFORMANCE							
Soleal Visible - Concealed hardware							
Open-in configurations	Size W x H in m		With Ug = 1,1 + Warm edge	With Ug = 1,0 + Warm edge	With Ug = 0,8 + Warm edge	With Ug = 0,6 + Warm edge	With Ug = 0,5 + Warm edge
			Glazing 24 mm	Glazing 24 mm	Glazing 32 mm	Glazing 42 mm	Glazing 48 mm
			SW-V	SW-V	SW-V	SW-V	SW-V
<b>Window</b>							
1 leaf	1,25 x 1,48	Uw (W/m².K)	1,5	1,4	1,4	1,1	1,1
		Sw	0,47	0,37	0,39	0,39	0,39
		TLw	0,58	0,52	0,52	0,52	0,52
2 leaves	1,53 x 1,48	Uw (W/m².K)	1,6	1,5	1,5	1,3	1,2
		Sw	0,43	0,34	0,36	0,36	0,36
		TLw	0,53	0,47	0,47	0,47	0,47
<b>Balcony door</b>							
1 leaf	1,25 x 2,18	Uw (W/m².K)	1,5	1,3	1,2	1,0	1,0
		Sw	0,49	0,39	0,41	0,41	0,41
		TLw	0,61	0,54	0,54	0,54	0,54
2 leaves	1,53 x 2,18	Uw (W/m².K)	1,4	1,4	1,3	1,2	1,1
		Sw	0,45	0,36	0,38	0,38	0,38
		TLw	0,56	0,49	0,49	0,49	0,49

Performance data obtained with a SW-V Spacer

THERMAL PERFORMANCE							
Soleal Minimal							
Open-in configurations	Size W x H in m		With Ug = 1,1 + Warm edge	With Ug = 1,0 + Warm edge	With Ug = 0,8 + Warm edge	With Ug = 0,6 + Warm edge	With Ug = 0,5 + Warm edge
			Glazing 26 mm	Glazing 26 mm	Glazing 32 mm	Glazing 42 mm	Glazing 42 mm
			SW-V	SW-V	SW-V	SW-V	SW-V
<b>Window</b>							
1 leaf	1,25 x 1,48	Uw (W/m².K)	1,4	1,4	1,2	1,0	
		Sw	0,5	0,4	0,43	0,43	
		TLw	0,64	0,56	0,57	0,57	
2 leaves	1,53 x 1,48	Uw (W/m².K)	1,5	1,4	1,2	1,1	
		Sw	0,47	0,38	0,41	0,41	
		TLw	0,6	0,54	0,54	0,54	
<b>Balcony door</b>							
1 leaf	1,25 x 2,18	Uw (W/m².K)	1,4	1,3	1,1	1,0	
		Sw	0,51	0,41	0,45	0,45	
		TLw	0,66	0,58	0,59	0,59	
2 leaves	1,53 x 2,18	Uw (W/m².K)	1,5	1,4	1,2	1,0	
		Sw	0,49	0,39	0,42	0,42	
		TLw	0,62	0,55	0,56	0,56	
<b>Balcony door with threshold</b>							
1 leaf	1,25 x 2,18	Uw (W/m².K)	1,4	1,4	1,2	1,0	
		Sw	0,51	0,41	0,45	0,45	
		TLw	0,66	0,58	0,59	0,59	
2 leaves	1,53 x 2,18	Uw (W/m².K)	1,5	1,4	1,2	1,1	
		Sw	0,49	0,4	0,43	0,43	
		TLw	0,62	0,55	0,56	0,56	

THERMAL PERFORMANCE							
Soleal Minimal - Clip-on Trim							
Open-in configurations	Size W x H in m		With Ug = 1,1 + Warm edge	With Ug = 1,0 + Warm edge	With Ug = 0,8 + Warm edge	With Ug = 0,6 + Warm edge	With Ug = 0,5 + Warm edge
			Glazing 26 mm	Glazing 26 mm	Glazing 32 mm	Glazing 42 mm	Glazing 42 mm
			SW-V	SW-V	SW-V	SW-V	SW-V
<b>Window</b>							
1 leaf	1,25 x 1,48	Uw (W/m².K)	1,4	1,4	1,2	1,0	
		Sw	0,5	0,4	0,43	0,43	
		TLw	0,64	0,56	0,57	0,57	
<b>Balcony door</b>							
1 leaf	1,25 x 2,18	Uw (W/m².K)	1,4	1,3	1,1	1,0	
		Sw	0,51	0,41	0,45	0,45	
		TLw	0,66	0,58	0,59	0,59	
2 leaves	1,53 x 2,18	Uw (W/m².K)	1,5	1,4	1,2	1,0	
		Sw	0,49	0,39	0,42	0,42	
		TLw	0,62	0,55	0,56	0,56	



Architect: A.D.H.  
Photography: DR Technal

## EPD (ENVIRONMENTAL PRODUCT DECLARATION)

Life-cycle indicators	Unit per window	Results
Non-renewable primary energy	(MJ)	1948
Renewable primary energy	(MJ)	129,5
Water consumption	(kg)	1819
Reduction in abiotic resources	(kg Sb eqv.)	1,009
Global warming potential	(kg CO2 eqv.)	200,6
Potential for ozone layer depletion	(kg R11 eqv.)	3,902E-005
Acidification potential	(kg SO2 eqv.)	0,7912
Eutrophication potential	(kg PO4 eqv.)	0,07797
Potential for photochemical ozone formation	(kg ethene eqv.)	0,09789
Non-hazardous waste	(kg)	6,853
Hazardous waste	(kg)	4,256

The indicators are based on average representative data for aluminium production in the European Union and generic data for a standard unit of glazing and standard seals.

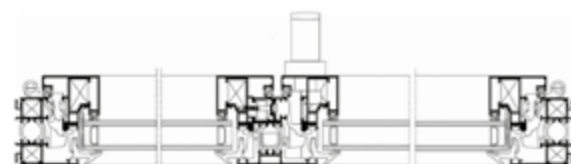

Horizontal cross-section of the tested system

## MATERIALS AND COMPONENTS

As with all Technal systems, only the best materials and parts are used to minimise maintenance and ensure long-term performance.

- The aluminium profiles are extruded from alloys 6060 Building compliant with EN 12020, EN 573-3, EN 515 and EN 775-1 to 9.
- Fittings are cast from EN 12844 compliant Zamak 5.
- All seals are EPDM or TPE (Thermoplastic elastomer).
- The polyamide thermal breaks are extruded from pA6-6 (0.25 FV).
- Screws are made from stainless steel.

## FINISHES AND COLOURS

A large range of finishes and colours are available to meet individual project requirements, enhancing existing buildings and offering architects and designers greater design freedom:

- Natural anodised in accordance with EN 23731: 2001.
- Polyester coating finishes in a wide range of colours in accordance with "QUALICOAT" instructions.
- SOLEAL is also available in laquered finishes with exclusive Technal colours for a stylish and contemporary look.



IMAGINE WHAT'S NEXT

270, rue Léon-Joulin  
BP 63709 - 31037 Toulouse cedex 1  
FRANCE - [www.technal.com](http://www.technal.com)

