

TOPAZE

CONTEMPORARY
SLIDER



Architect: Bruno Marques
Photographer: AFFP Filipe Pombo

IMAGINE WHAT'S NEXT

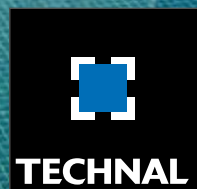



TOPAZE

/ SOBRIETY, SIMPLICITY
AND ADAPTABILITY

TOPAZE has proven itself to be the ideal system for external composite frames in hot climates and is suitable for tropical zones: cyclone resistant, installations with SAFETYLINE louvres, integration with louvre or blade infills for ventilation or solar protection and the integration of mosquito screens.

TOPAZE+, EXCEPTIONAL JOINERY

TOPAZE+ offers solutions to specific market needs. Thanks to the combination of glazing up to 24 mm thick and rollers that are able to support leaves weighing up to 200 kg, TOPAZE+ is the ideal solution for large frame sizes with 1 to 8 leaves with comfort requirements (thermal insulation, acoustics and security).

As an alternative to rounded opening frames, the TOPAZE+ follows architectural trends by offering an opening frame showcasing a straight edged design. A choice of product lines which provide the finishing touch thanks to the finesse of the mullions.

TOPAZE 20 MM, EFFICIENCY AND SIMPLICITY

The TOPAZE 20 mm is a complete range of traditional sliding systems with 1 to 4 tracks for the construction of windows or patio doors supporting leaves weighing up to 140 kg, with glazing from 5 mm to 20 mm thick.



Architect: Bruno Marques
Photography: AFFP Filipe Pombo

Architects: Lacaton & Vassal Architectes Associés
Photographer: Philippe Ruault

TOPAZE

/ CONTEMPORARY SLIDER

TOPAZE 20 MM

* Straight version available

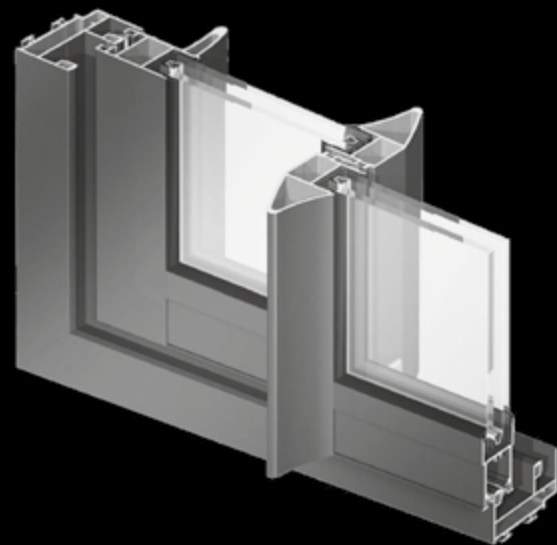

TOPAZE+

* Rounded version available

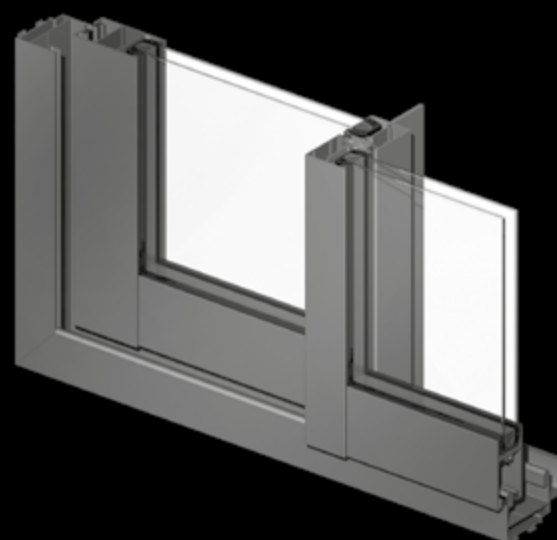

KEY FEATURES AND INNOVATIONS

2 VERSIONS OF OPENING FRAMES

- 1 version up to 20 mm.
- 1 version up to 24 mm.

MULTIPLE CONFIGURATIONS

- 2, 3 or 4 tracks.
- Composite assemblies.
- Full-access version on 1 or 2 tracks.
- Configurations with Safetyline louvres.
- Integrated louvre or blade infills for ventilation or solar protection and integrated mosquito screens.

WEATHER PERFORMANCE

- Having undergone category 5 cyclone resistance testing, along with the combination of special reinforced mullions (lateral and central) and a double brush gasket with a central strip offering enhanced water tightness means that this slider can withstand cyclonic wind and rain.

AESTHETICS

- Choice of 2 types of opening frames for improved cohesion with architectural styles.

CLOSURE SYSTEMS

- TOPAZE 20 mm and TOPAZE+:
 - Single or double recessed handle with a lock and automatic closure system (window).
 - Multipoint closure systems (3 or 4 points) with handle and lock for enhanced security.
 - Recessed pull handle.
- TOPAZE+
 - Half moon handle (only on rounded mullions) with a single-action unlocking system for the easy manipulation of service leaves (Technal patent).

TOPAZE+

EXCEPTIONAL JOINERY

- Subjected to 20000 cycles of opening and closing tests, this sliding system guarantees longevity and ease of use with leaves weighing up to 200 kg.
- Available in the traditional version, full-access version and outer-fixed frame application, the use of 6 mm to 24 mm glazing makes it possible to add acoustic, insulation and reinforced security solutions.
- Attention to finishing touches: all accessories are painted to match the sliders' finish, all fixings are concealed, glazing gaskets are discreet thanks to the minimal flashing.



Architect: Carlos Gilardi
Photography: DR Technal

ATTENTION TO DETAIL

- Locking mechanisms: simple 1-point recessed handle, up to 4-point closure systems with handles and locks.
- Recessed track (stainless steel, aluminium) for greater durability.



Half-moon handle on slider, curved design only



Recessed handle for multi-point closure systems



Single recessed handle

THE DIVERSITY OF CREATIONS

As an alternative to rounded opening frames, the TOPAZE+ follows architectural trends with the version of the opening frame featuring straight edges. A selection of lines which providing the finishing touch to the meticulous aesthetics thanks to the finesse of the mullion.

STRAIGHT DESIGN

- 41 mm central mullion, very clean lines.
- Straight lateral mullion.
- Reinforced central and lateral mullions for large scale designs.

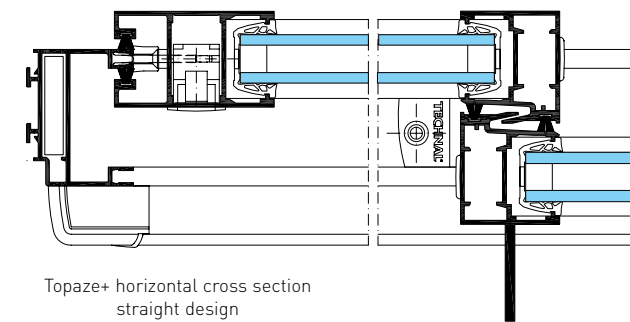

Topaze+ horizontal cross section straight design

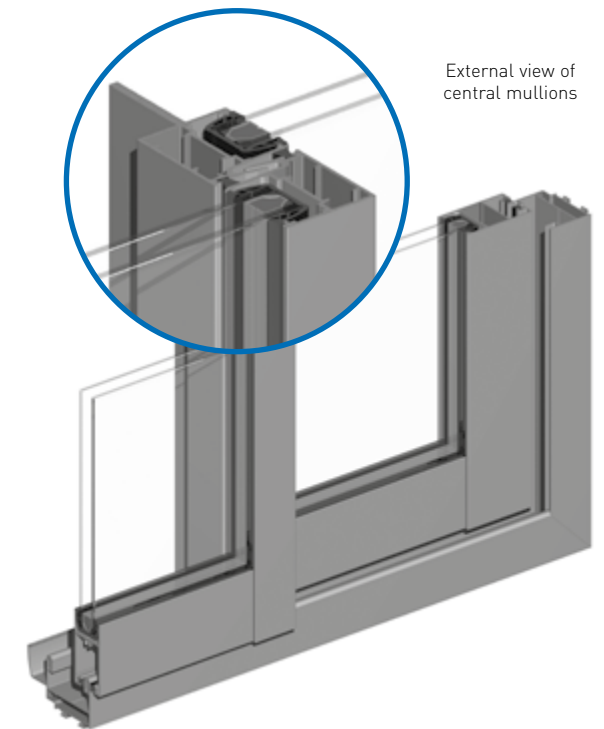

External view of central mullions

ROUNDED DESIGN

- Central mullion 41 mm, narrow front edge, strong profile.
- Curved lateral mullion.
- Reinforced central and lateral mullions for large scale designs.

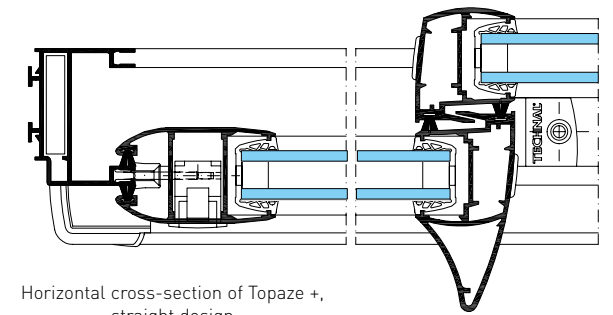

Horizontal cross-section of Topaze +, straight design

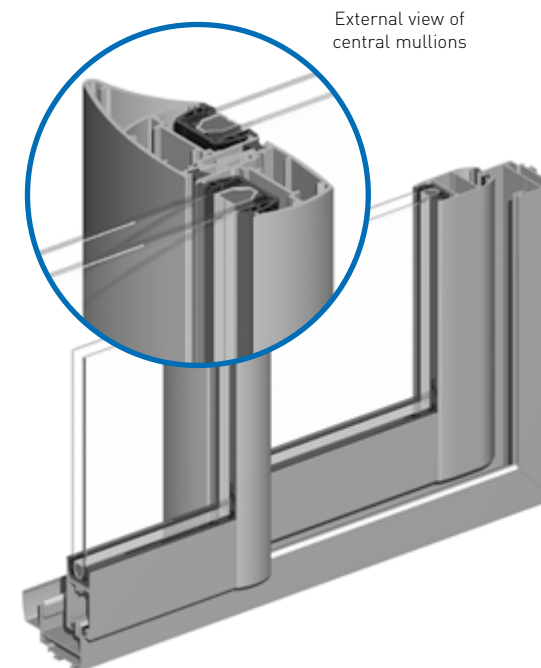

External view of central mullions

SECTIONS OF THE TOPAZE+

PATIO DOOR, 2 LEAVES - 2 TRACKS

Cyclone resistant

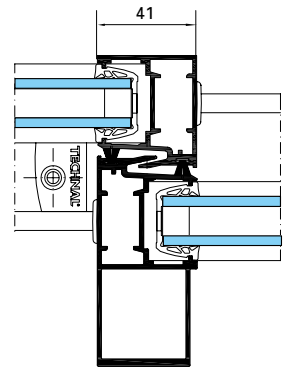

Rounded design

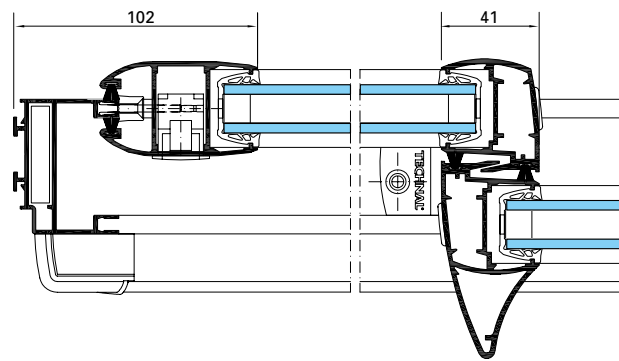

Straight design

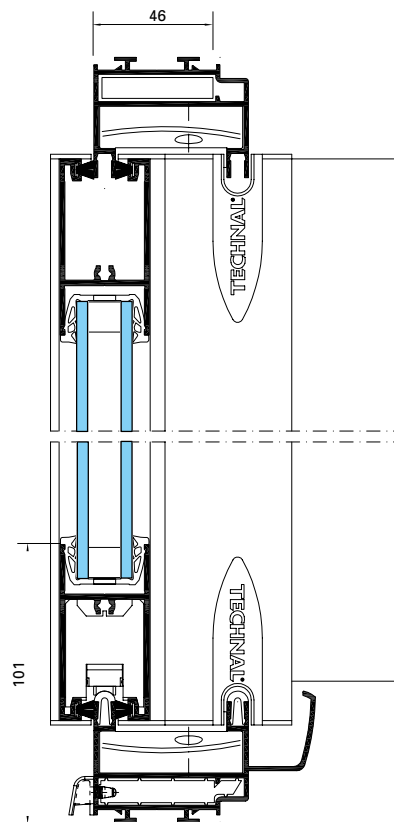
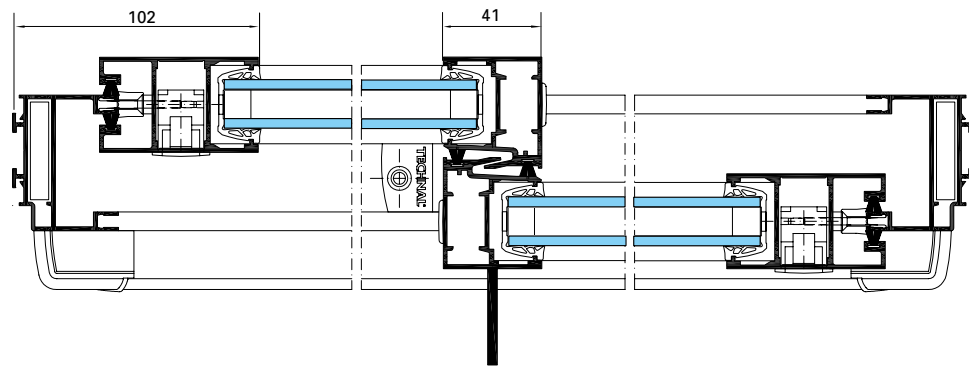

4 LEAVES - 2 TRACKS

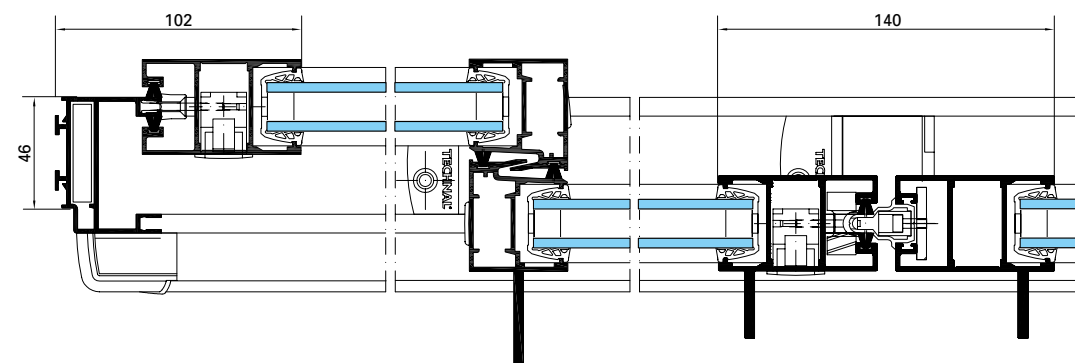

3 LEAVES - 3 TRACKS

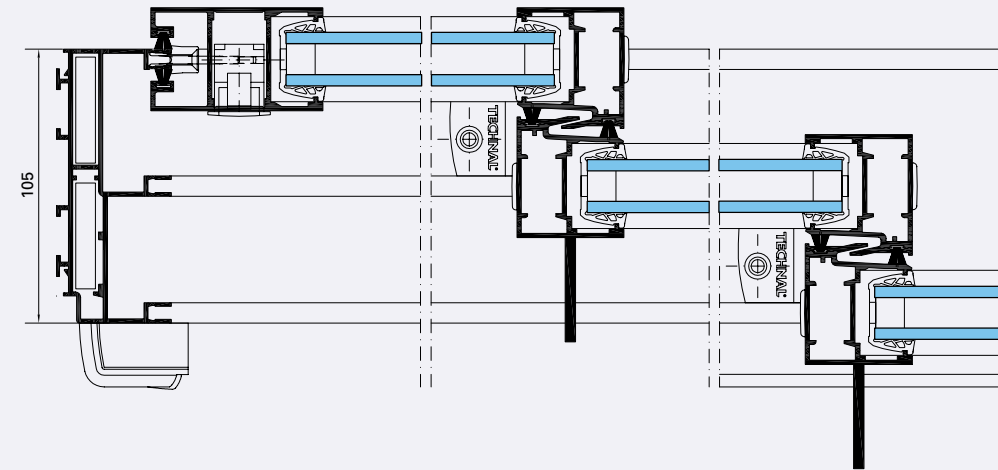

4 LEAVES - 4 TRACKS

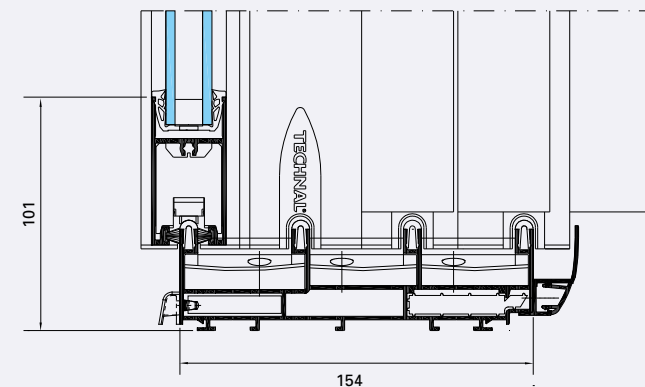
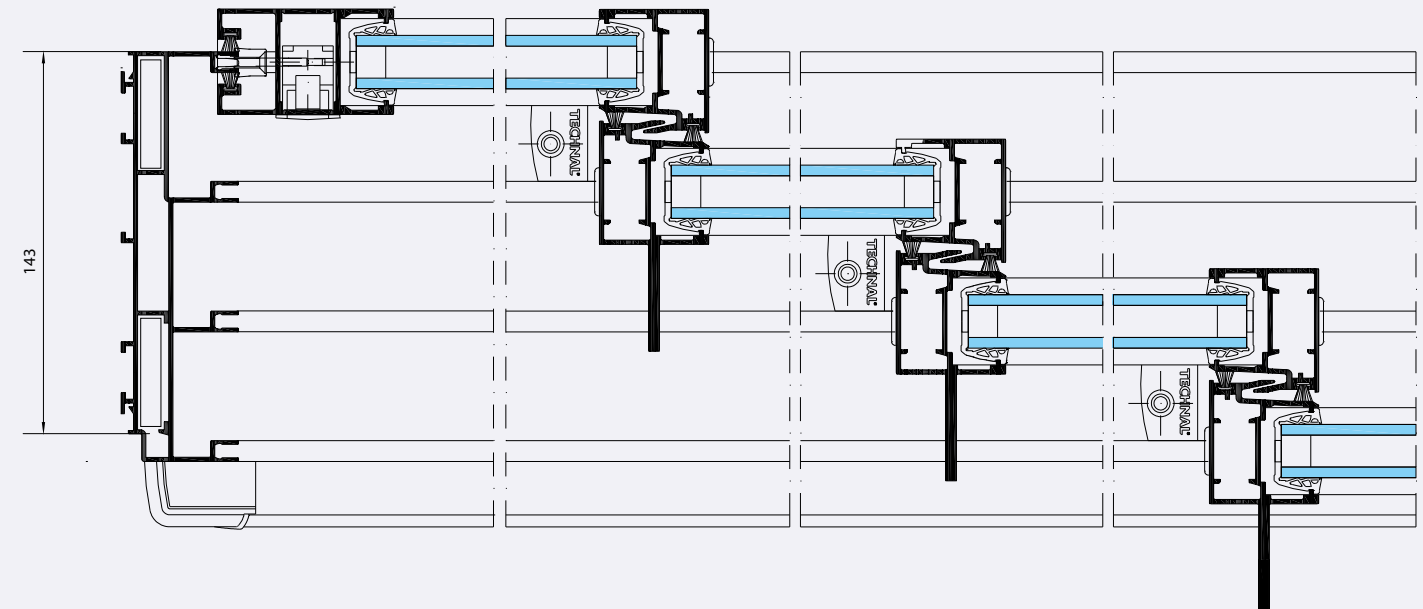

SECTIONS TOPAZE+

FULL-ACCESS VERSION - MONORAIL - 1 LEAF

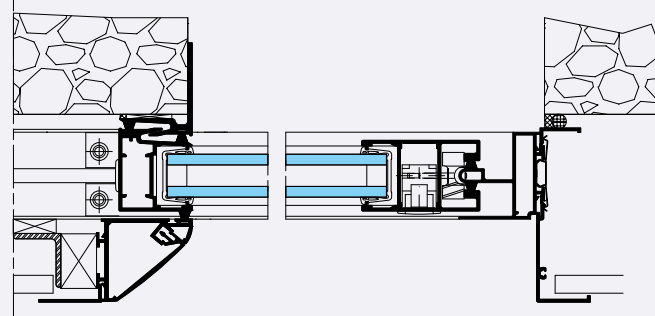

FULL-ACCESS VERSION - MONORAIL - 2 LEAVES CENTRAL PERCUSSION

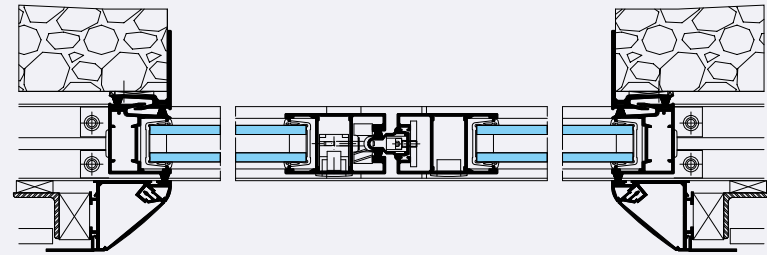

FULL-ACCESS VERSION - 2 RAILS - 2 LEAVES

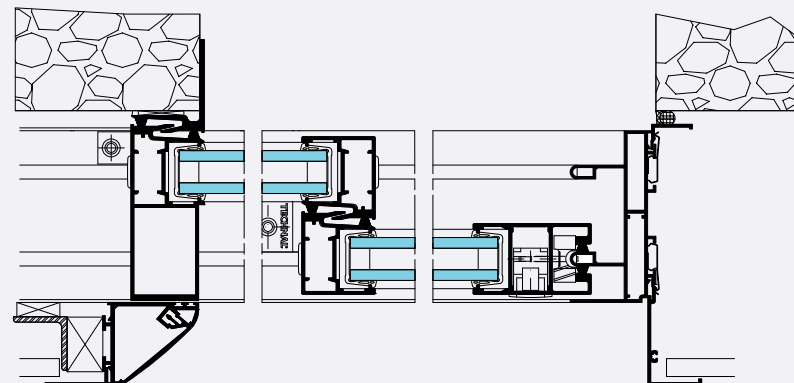

OUTER-FIXED FRAME - MONORAIL

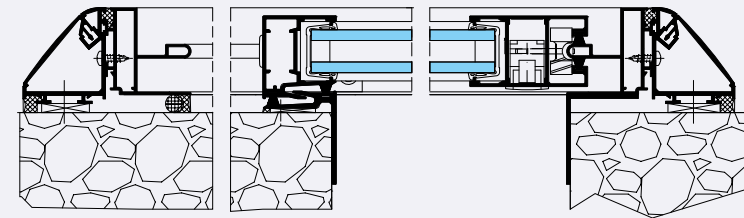

OUTER-FIXED FRAME - 2 RAILS - 4 LEAVES

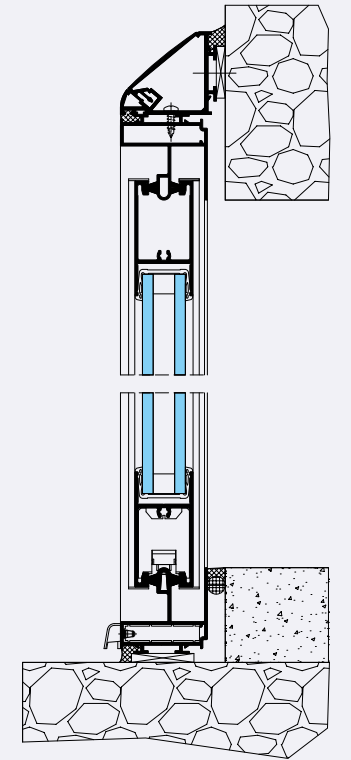
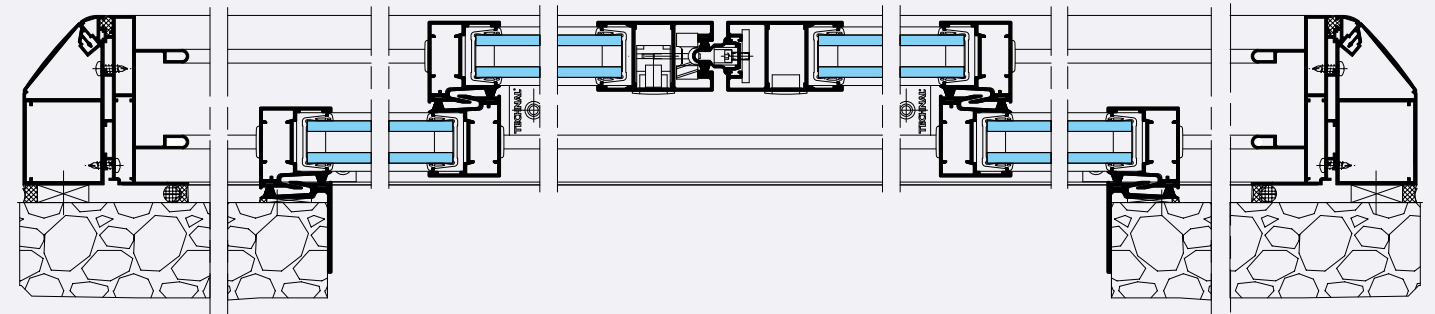

TOPAZE 20 MM

EFFICIENT AND AESTHETIC

- Rollers supporting the weight of the leaves weighing up to 140 kg.
- Aluminium tracks for 1 to 8 leaves.
- Glazed infill from 5 to 20 mm thick.
- Sound reduction of up to 35 dB(A) for the comfort of the occupant.
- Optimised glazed area due to the thin design of the central and lateral mullions therefore maximising light.
- Choice of 2 types of opening frames for improved cohesion with architectural styles.

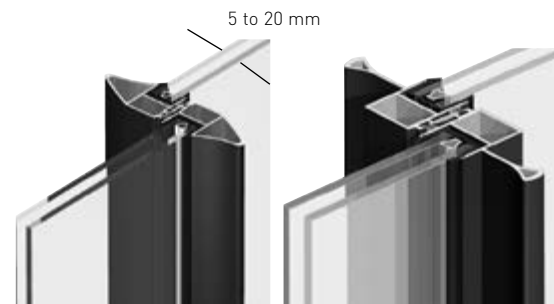

Reinforced central mullions

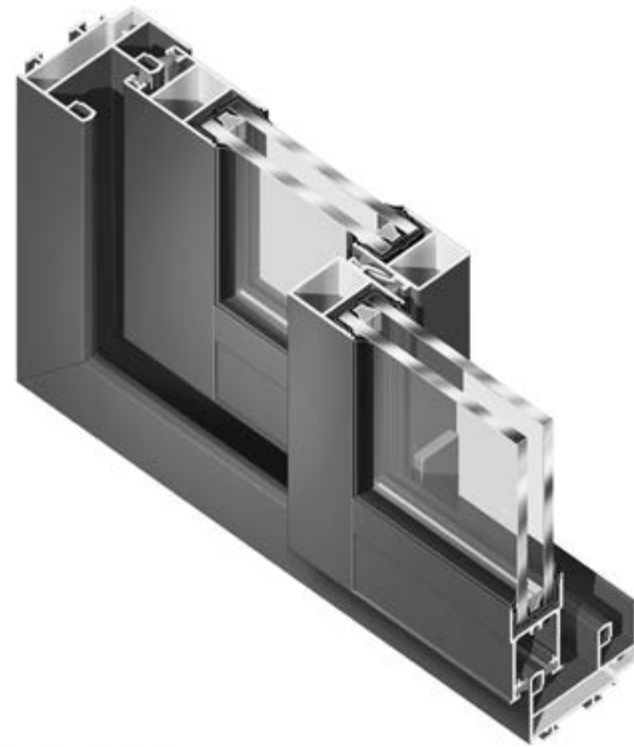

A COMPREHENSIVE RANGE OF LOCKING MECHANISMS

- Single or double recessed handle with a lock and automatic closure system (window).
- 3-point locking system for increased security.
- Recessed pull handle (window and patio door).



SUITABLE FOR TROPICAL ZONES

- Having undergone category 5 cyclone resistance testing, along with the combination of special reinforced mullions (lateral and central) and a double brush gasket with a central strip offering enhanced water tightness means that this slider can withstand cyclonic wind and rain.
- The reinforced inertia of the mullions means that we can produce sliding systems up to 2.60 m high without a loss of performance.
- This slider offers solutions that are particularly suited to tropical zones: configurations with SAFETYLINE louvres, integrated louvre or blade infills for ventilation or solar protection and integrated mosquito screens.

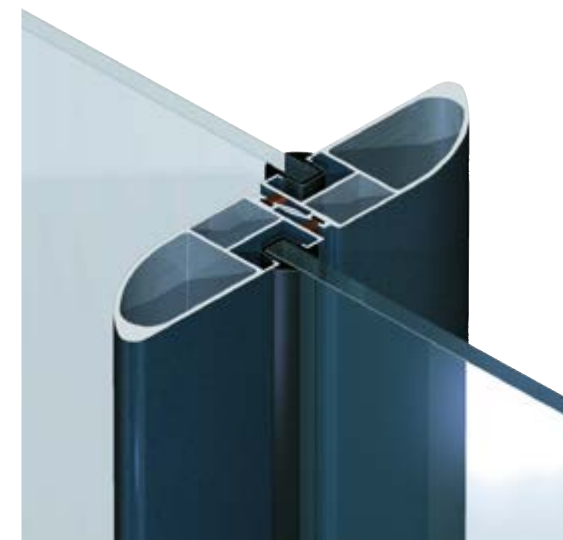

Cyclone resistant central mullions

SECTIONS TOPAZE 20 MM

2 LEAVES - 2 TRACKS

Reinforced central mullions

Basic design

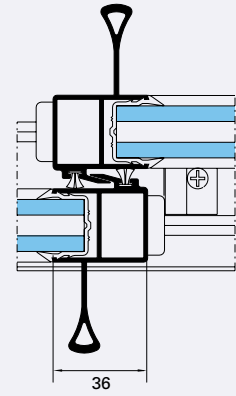

Rounded Design

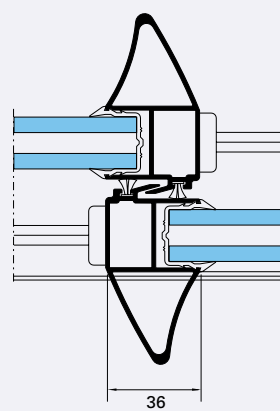

Cyclone resistant

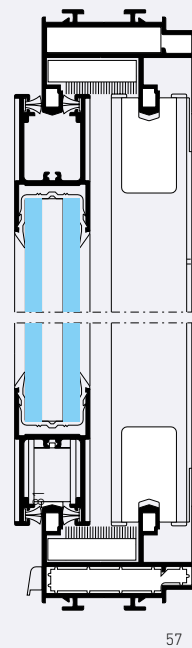
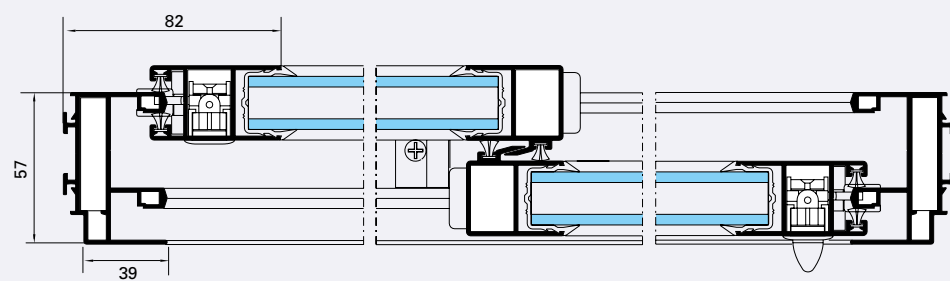
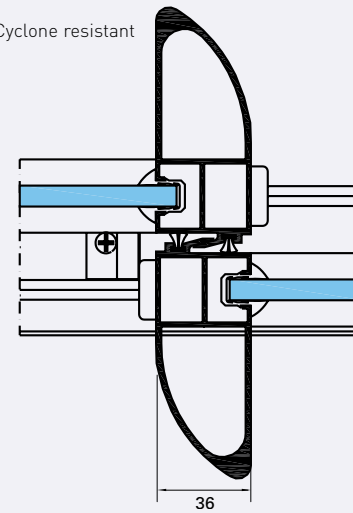

4 LEAVES - 2 TRACKS

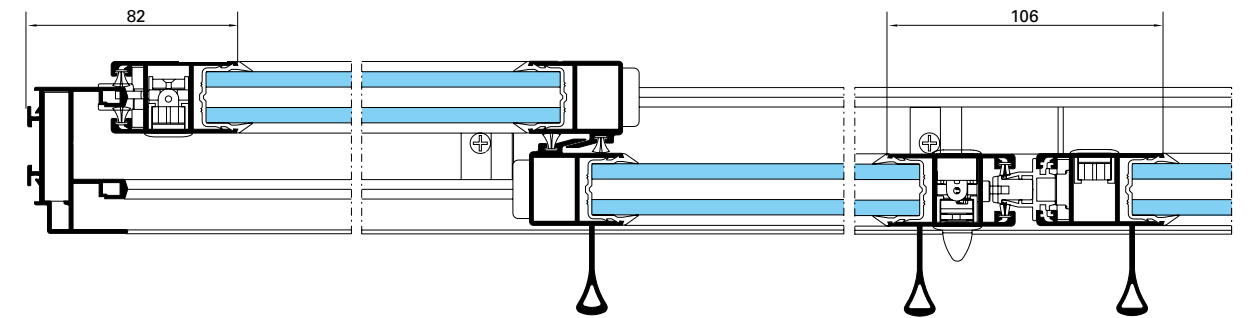

3 LEAVES - 3 TRACKS

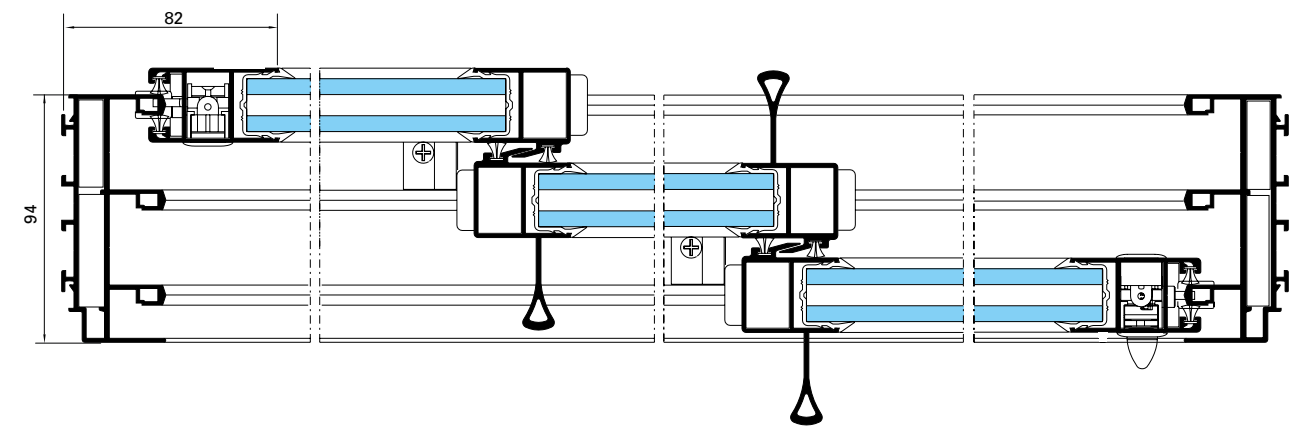

4 LEAVES - 4 TRACKS

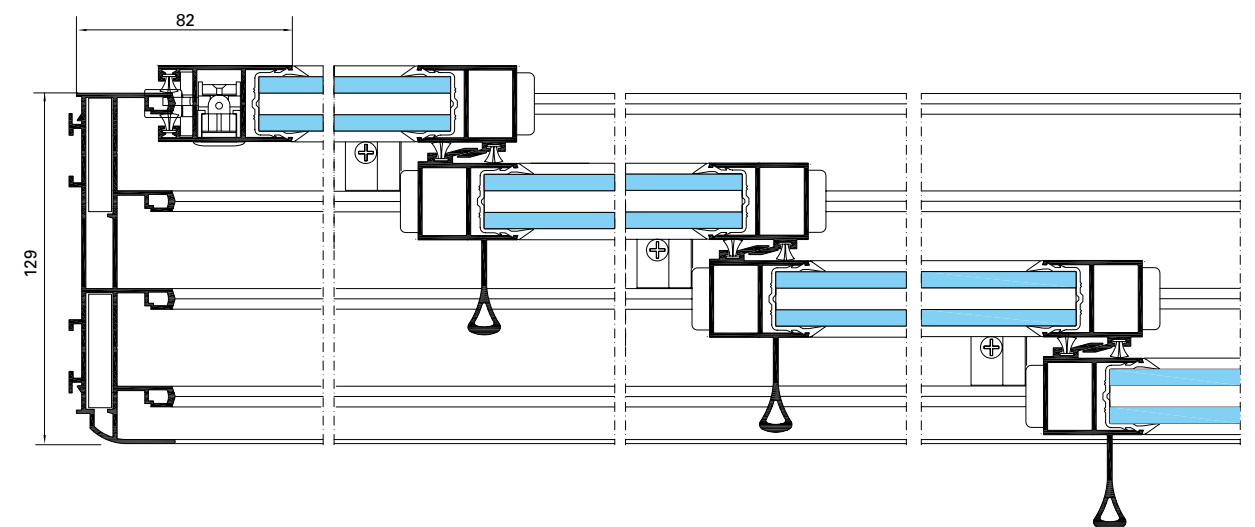

CONFIGURATIONS

TOPAZE+

2 TRACKS

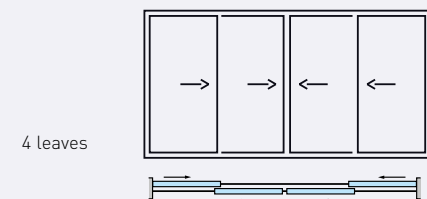
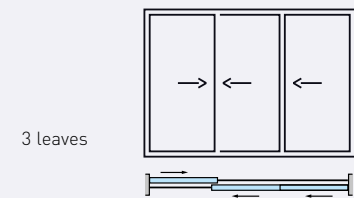
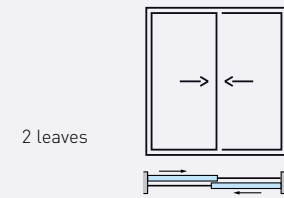

3 TRACKS

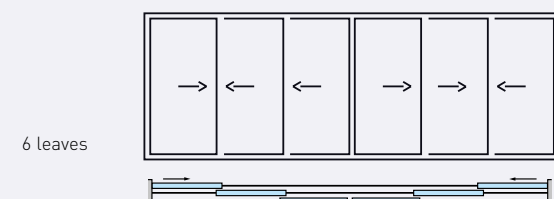
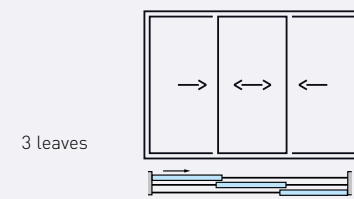

4 TRACKS

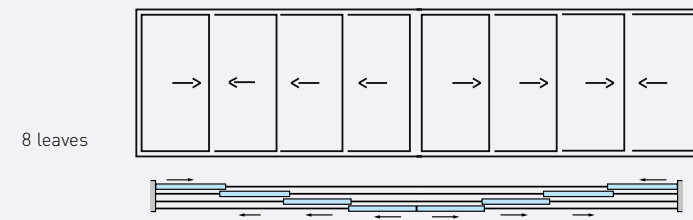
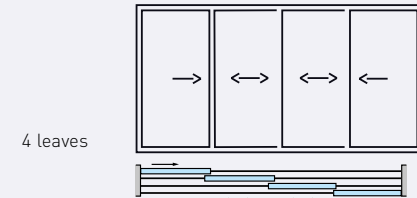

FULL-ACCESS VERSION AND OUTER-FIXED FRAME

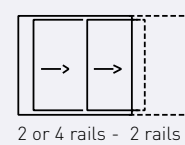
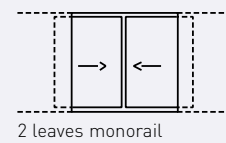
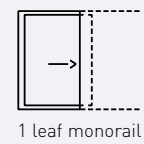

TOPAZE 20 MM

2 TRACKS

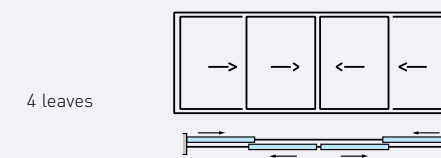
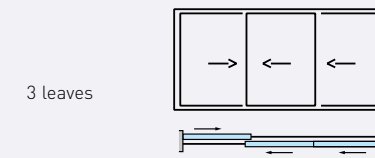

3 TRACKS

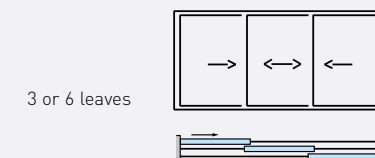

4 TRACKS

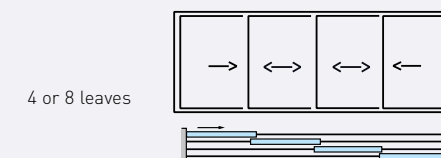

COMPOSITE FRAMES

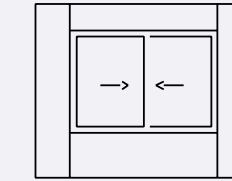

FULL-ACCESS VERSION

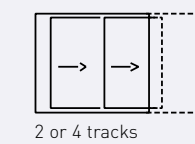
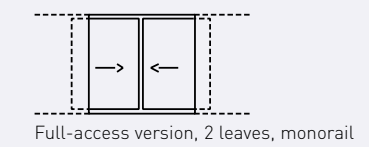
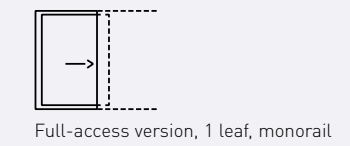

INTEGRATION OF INFILLS FOR SHUTTERS

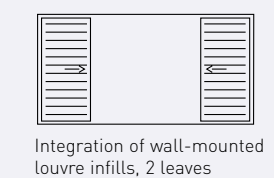
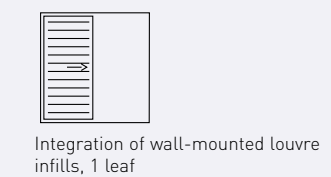

PERFORMANCE

TOPAZE 20 MM

WEATHER PERFORMANCE: A.E.V. (A: Air, E: Water, V: Wind)					
Type	Dimensions W x H in m	Air permeability	Water tightness	Wind resistance	P.V. n°
Patio door, 2 cyclone resistant leaves 2.20 x 2.15 H	2.20 x 2.15	Class 3	Class 4A	Class A5	E213.4.039
Window, 2 cyclone resistant leaves 1.40 x 1.40 H	1.40 x 1.40	Class 2	Class 7B	Class C5	E213.4.262
Cyclone resistant door-closers, 3 leaves, 3 tracks 3.15 x 2.22 H	3.15 x 2.22	Class 4	Class 7B	Class A5	B225.4.032
Patio door, 4 leaves, 2 tracks 3.60 x 2.40 H	3.60 x 2.40	Class 4	Class 5A	Class C3	B222.8.014
Patio door, 2 leaves, 2 tracks 2.10 x 2.20 H	2.10 x 2.20	Class 3	Class 5A	Class A2	E213.2.264

ACOUSTIC PERFORMANCE					
Type	Glazing	Test report number	dB results		
			RA, tr	RA	RW
Outer frame with drainage	Climalit 4/12/4	624475	28	28	29
Outer frame	35-20 4/6/10	624281	33	35	35
Outer frame Sliding gasket + beading	35-20 4/6/10	624776	35	36	36

Tested in accordance with standards NF - S31-051 - EN ISO 140 - EN ISO 177 - 2-leaf window H = 1480 x W = 1470

TOPAZE+

PERFORMANCES A.E.V. (Air, Eau, Vent)					
Type	Dimensions W x H in m	Air permeability	Water tightness	Wind resistance	P.V. n°
Patio door, 2 leaves H = 2.15 - W = 1.80	1,80 x 2,15	Class 3	Class A7	Class C3	E223-01-024

ACOUSTIC PERFORMANCE					
Type	Glazing	Report no.	dB results		
			RA, tr	RA	RW
Standard outer frame	38 - 23	625329	33	32	33
Standard outer frame	35 - 20	625331	33	31	33
Standard outer frame	4.12.4	625328	31	29	31
Standard outer frame	4.12.4	625330	31	29	31

Tested in accordance with French and European standards NFS31-051 - EN ISO 140 - EN ISO 717 - 2-leaf window H = 1480 x W = 1470

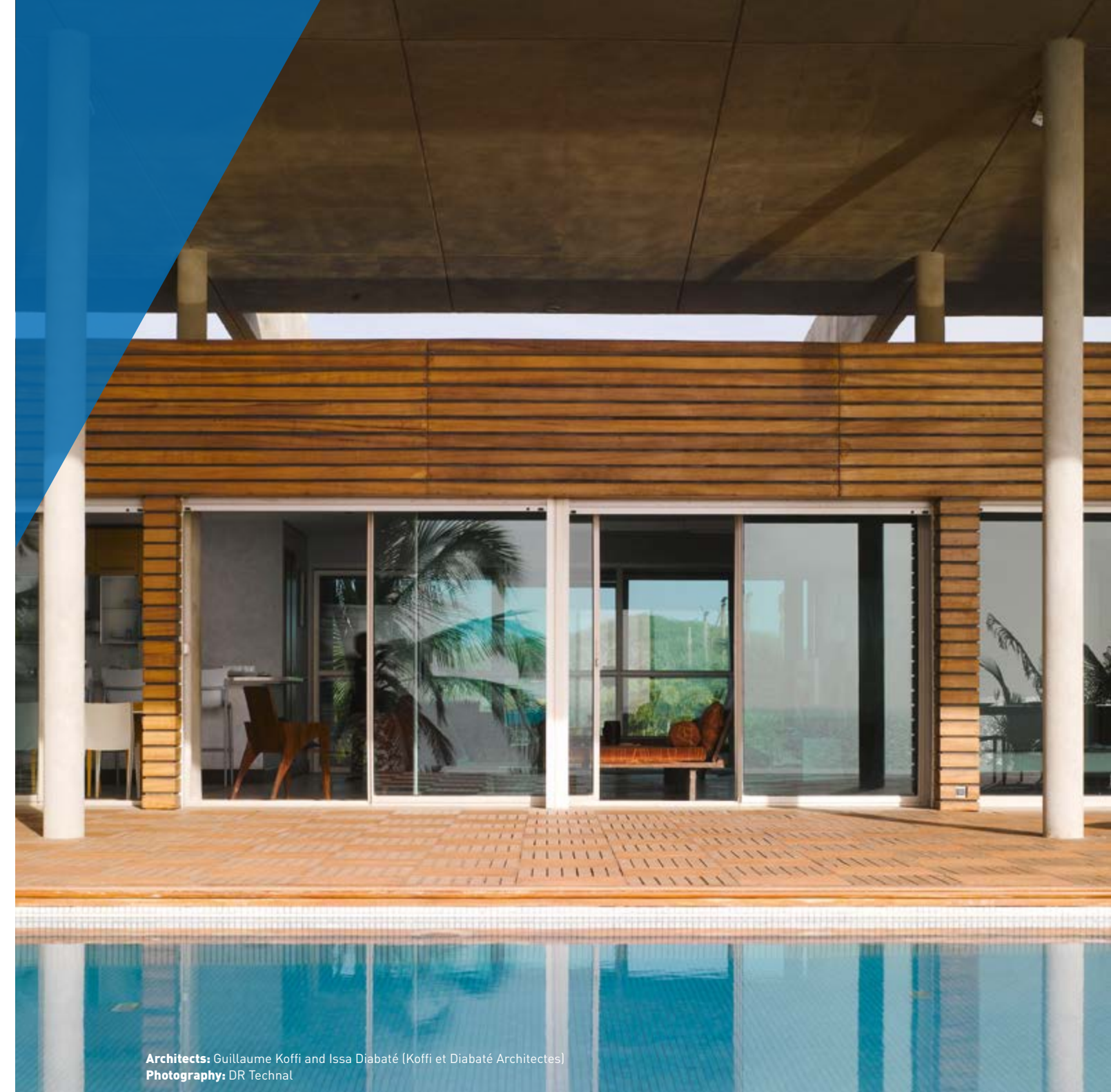

Architects: Guillaume Koffi and Issa Diabaté (Koffi et Diabaté Architectes)
Photography: DR Technal

MATERIALS AND PARTS

As with all Technal systems, only the highest materials and components are used to minimise maintenance and ensure long-term performance.

- Aluminium profiles are extruded from EN AW 6060 according to standards EN 12020, EN 573-3, EN 515 and EN 775-1 to 9 alloys.
- Fittings are cast from EN 12844 compliant Zamak 5.
- EPDM or TPE gaskets (Thermoplastic elastomer).
- Screws are made from stainless steel.

FINISHES AND COLOURS

A wide range of finishes and colours is available to meet individual project requirements, enhancing existing buildings and offering architects and designers greater design freedom:

- Natural anodised in accordance with EN 123731: 2001.
- Polyester powder coating finishes in a wide range of colours in accordance with "QUALICOAT".
- TOPAZE is also available in lacquered finishes with exclusive Technal colours for a stylish and contemporary look.

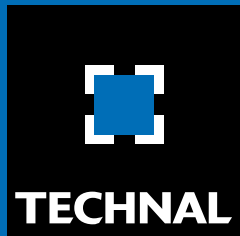

IMAGINE WHAT'S NEXT

270, rue Léon-Joulin
BP 63709 - 31037 Toulouse cedex 1
Tél. 05 61 31 28 28 - www.technal.com



By  Hydro