

# OPALE

PARTITION SYSTEM





## **OPALE**

/ AN EXTENSIVE RANGE  
OF INTERNAL ARCHITECTURAL  
SOLUTIONS

### **A COMPLETE SOLUTION**

The Opale partition offers an infinite amount of internal architectural solutions: partitions with an aluminium frame or with glazed panels fixed side by side. The possibility of integrating solid or glazed infills, as well as aluminium or glass doors, makes the Opale partition the ideal internal architectural solution. With its 3 assembly systems - standard partition, with a narrow rail or recessed junctions - the Opale partition offers huge scope for creative flexibility to meet whatever kind of architectural effect you are hoping to achieve.

The Opale partition system can also accommodate hinged doors and sliding doors.

Elegant and versatile, the Opale range is designed for a range of different markets: hospitals, offices, commercial premises, museums, etc.



Photography: DR Technat



# OPALE

/ PARTITION SYSTEM



## KEY FEATURES

### DESIGN

- The possibility of creating framed partitions or using glazed panels fixed side by side for a sleek design.
- 3 types of applications: standard partition, with a narrow rail or with a recess junction (Technal patented system).
- A huge variety of infills: plasterboard or woodchip panels, composite materials, clear glazing, screen printed designs or safety glass (in accordance with current standards).
- It is possible to integrate doors made from safety glass (6.6 or 8.8 mm), wooden doors (40 mm) or those with an aluminium frame. These applications are available in hinged and full-access versions.

### MODULARITY

- The partition starting from walls or multi-departing (2 to 4).
- Possibility of continuing on from a 100 mm plasterboard partition 100 mm.
- No modification or cutting work required for installation.
- Installation modifications can be made and modules can be interchanged easily.

### PERFORMANCE

- Moveable and removable partition: CER.F.F. C.07-433R.
- ETA: European Technical Approval n° ETA - 07/0308.
- Acoustics: Up to 44dB for solid standard partitions with plasterboard panels.
- Mechanical stability: shock resistance to hard and soft body impacts as well as horizontal pressure without permanent deformation or surface alteration.
- Fire resistance:
  - Schott flame guard test carried out on an Opale partition system with glazed panels fixed side by side.
  - Class E 30 (PF30).

# OPALE

/ PARTITIONS

## 3 SYSTEMS TO ADAPT TO ALL TYPES OF PROJECTS

### STANDARD PARTITION

An infinite range of configurations and combinations is possible:

- Solid or glazed modules: full height, on a solid apron wall, multi-transom or glazed panels fixed side by side.
- Easy to move and to disassemble.



### FLAT PARTITION WITH NARROW RAIL AND PICTURES RAIL

- High level of finish with the floor and the possibility of adding decorative touches.
- Solid or glazed modules with full-height versions available (fixed or moveable), on a solid apron wall (glazed partition), multi-transom or glazed panels fitted side by side.
- Actuation systems for adjusting the flat partitions.
- Moveable and removable.



### FLAT PARTITION WITH WOODEN RECESS JUNCTION

High-end aesthetics for internal architecture:

- Solid full-height module.
- Moveable and removable.



## AESTHETICS AND COMFORT

- Vertical or horizontal frames which can be customised with different beads.
- Corner enhancement with straight or round aesthetics.
- Possibility of integrating blinds or lighting between two glazed panels.
- Separation of different electrical and computing wiring using a cable channel.



Cable channel

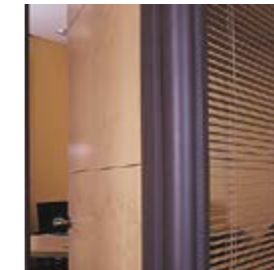

Built-in blind



Featured beads



Architects: SCI La Scuderia, J. Chabanne  
Photographer: S. Demailly

# OPALE

## / INCORPORATION OF DOORS

Opale partition systems can accommodate 3 types of doors:

- A wooden door that is 40 mm thick
- A safety glass door that is 6.8 or 8.8 mm thick.
- Doors with aluminium frames.
- These applications are available in hinged and full-access versions.

### HINGED DOOR

- 1 and 2-leaf applications.
- Varied selection of finishes and ergonomic handles: door knobs, push-down handles, pull handles.
- Pre-machined unit (push-down handle, door knob).
- Common frame for all types of opening frame.



**Architects:** Cabinet Dalmasa-Grazian  
**Photographer:** Serge Demailly

### FULL-ACCESS SLIDING DOOR

The opening frames fit seamlessly within the partition.

- 1 and 2-leaf applications with or without mullion.
- Maximum dimensions: H 3 m x width 1.2 m.
- Maximum weight per leaf: 100 kg.
- Easy to operate using a roller bearing system.
- Easy opening thanks to the pull handle with an optional lock.
- Common frame for all types of opening systems.



**Architects:** Cabinet Majorelle  
**Photographer:** Xavier Boymond

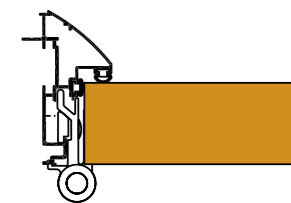

Wooden door

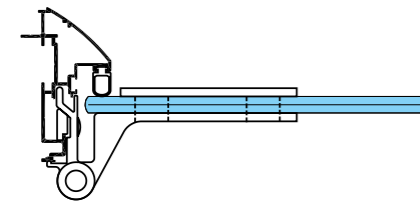

Glass door

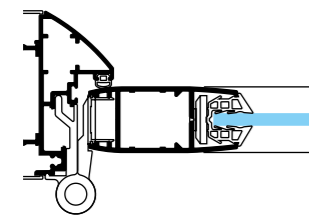

Aluminium door



Pull door handle



Door handle



Door knob

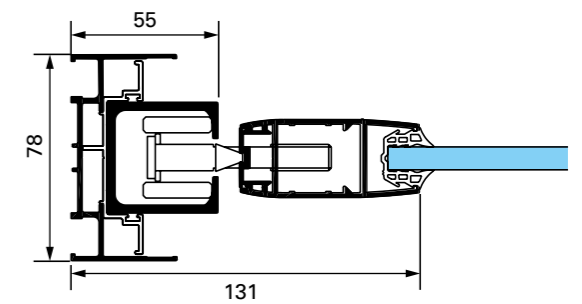

Cross-section of a sliding door

# SECTIONS

## STANDARD PARTITION

Full-height glazed module in a frame or fixed side by side

Full-height solid module

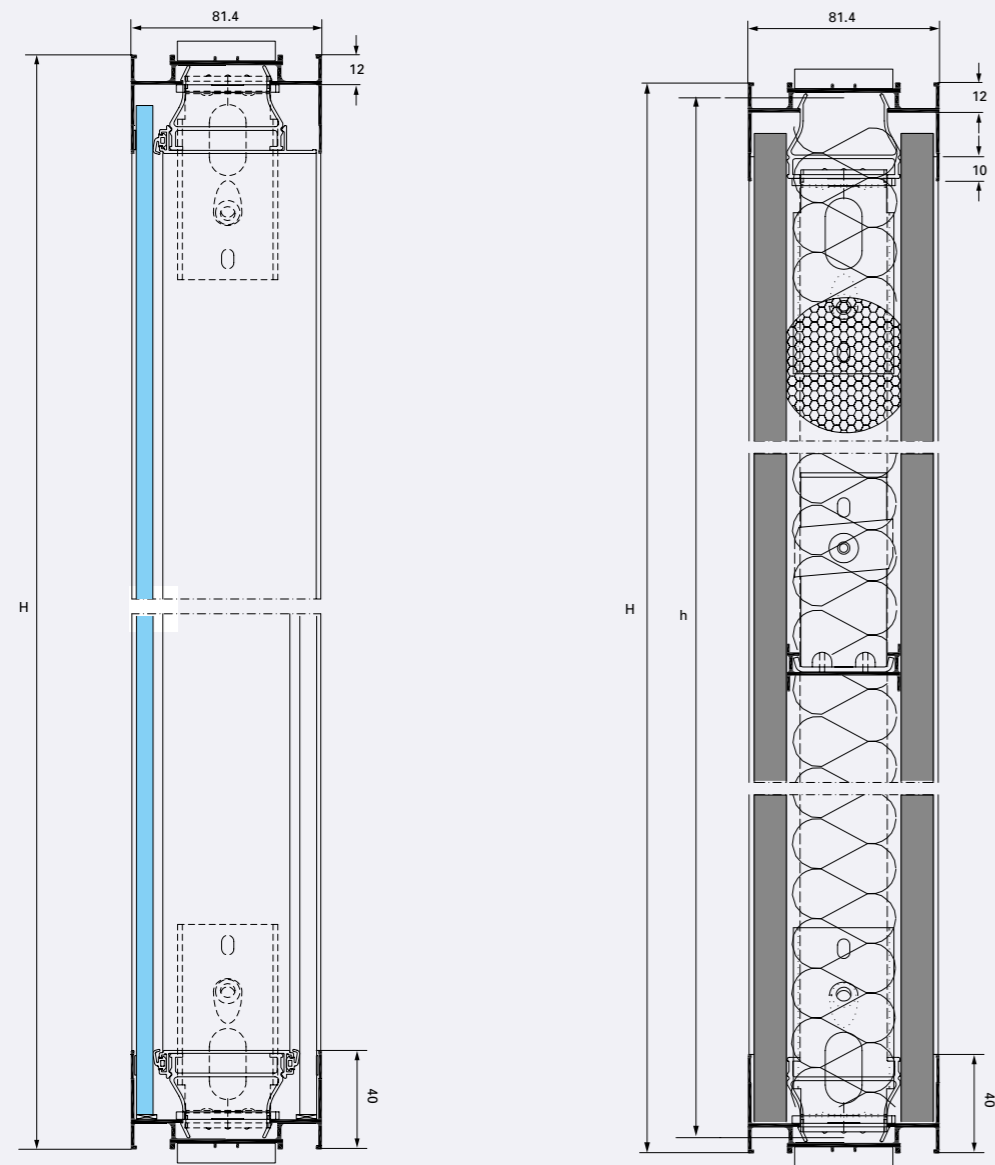

## FLAT PARTITION WITH NARROW RAIL

Full-height glazed module

Full-height solid module

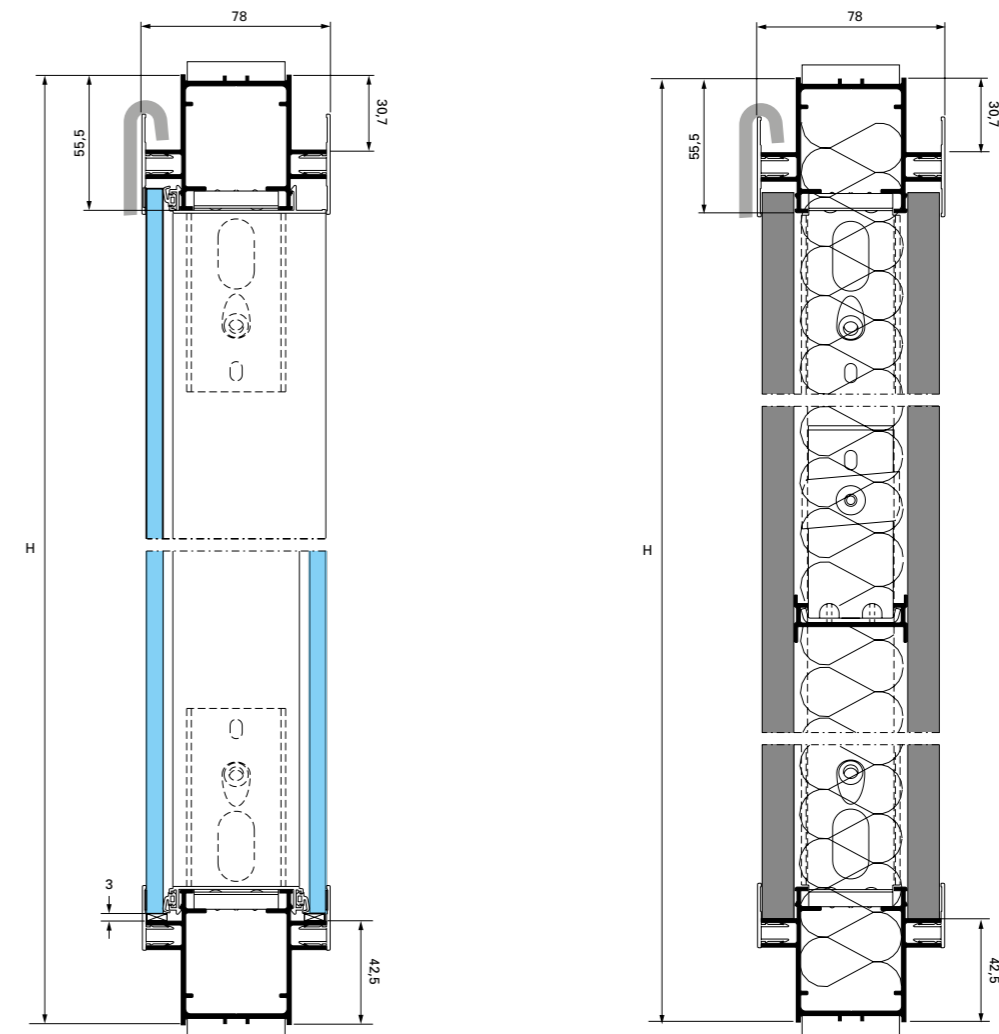

## FLAT PARTITION WITH RECESS JUNCTION

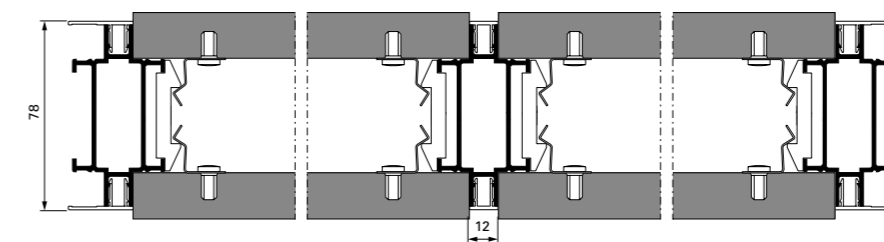



# SECTIONS

## HINGED DOORS

Wooden door

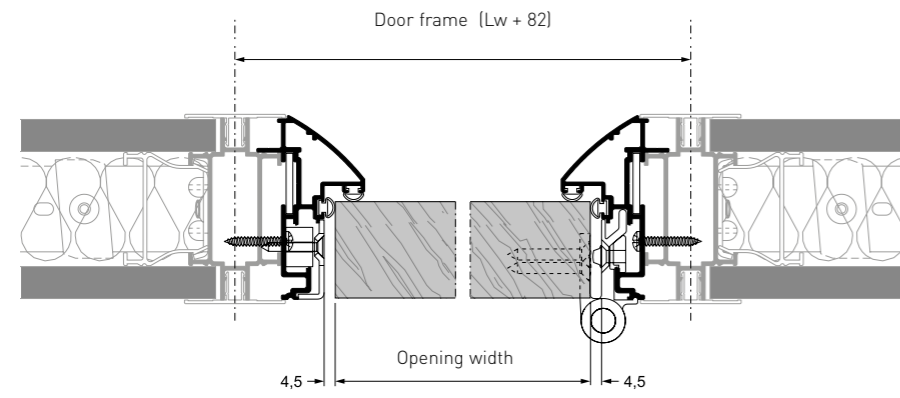

Glass door

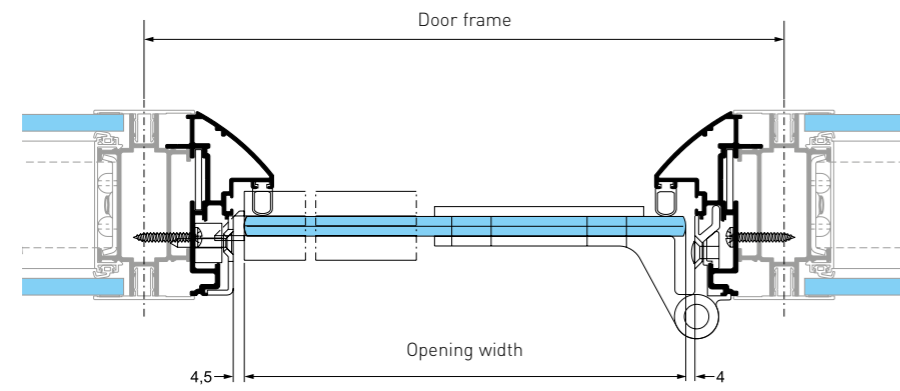

Aluminium door

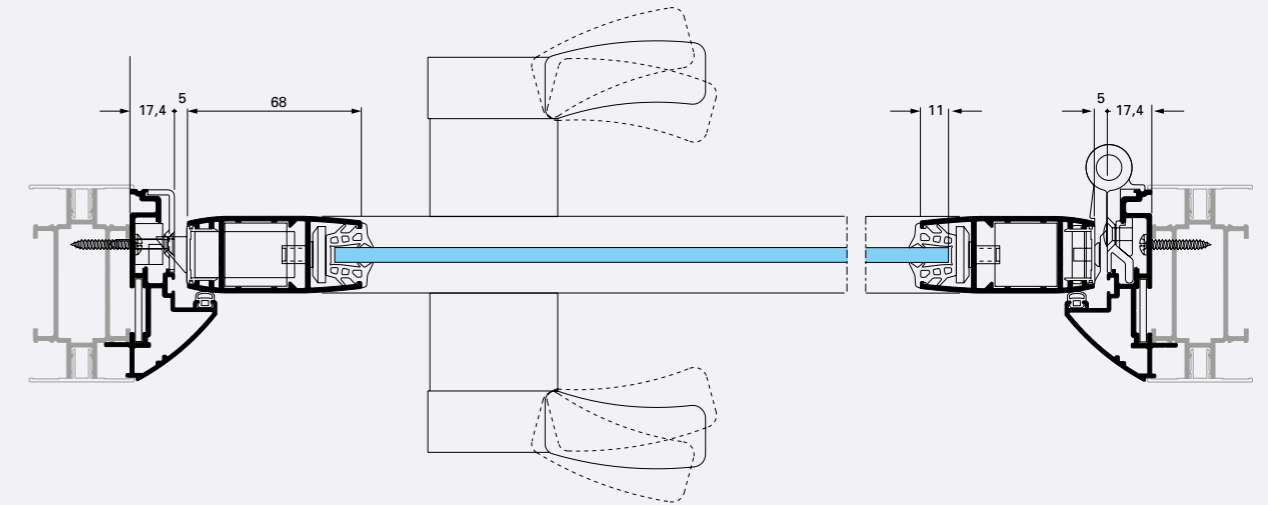

Full-access sliding door

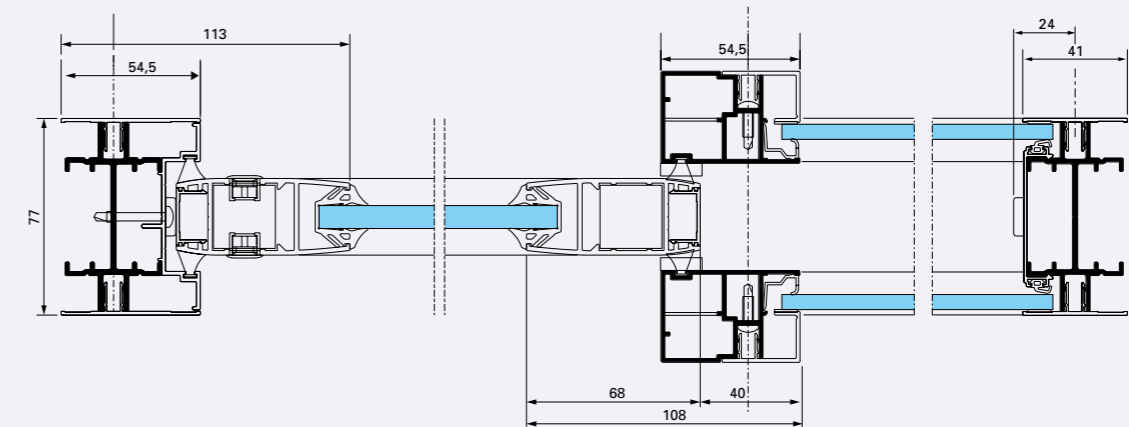

# APPLICATIONS

## STANDARD PARTITION

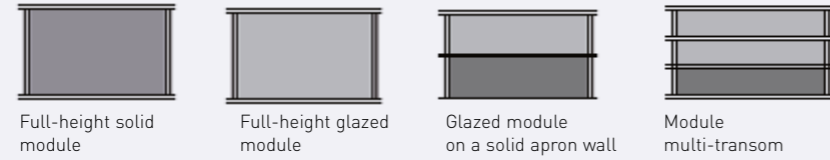

Full-height solid module    Full-height glazed module    Glazed module on a solid apron wall    Module multi-transom

## FLAT PARTITION WITH NARROW RAIL

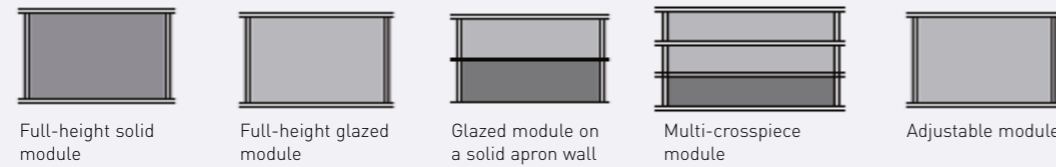

Full-height solid module    Full-height glazed module    Glazed module on a solid apron wall    Multi-crosspiece module    Adjustable module

## FLAT PARTITION WITH RECESS JUNCTION

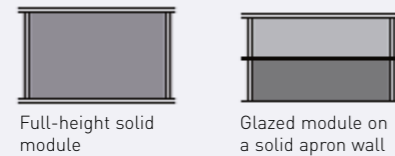

Full-height solid module    Glazed module on a solid apron wall

## HINGED DOORS

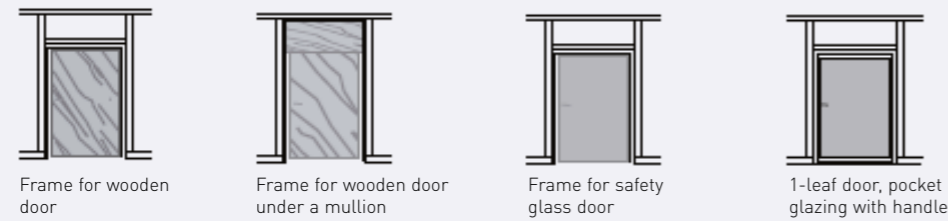

Frame for wooden door    Frame for wooden door under a mullion    Frame for safety glass door    1-leaf door, pocket glazing with handle



2-leaf door, pocket glazing with handle    1-leaf door, pocket glazing with knob    2-leaf door, pocket glazing with knob

## FULL-ACCESS SLIDING DOOR

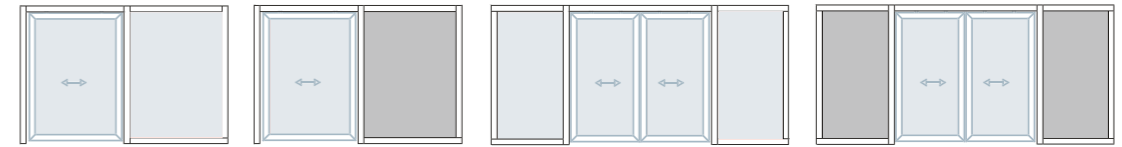

Full-access sliding door  
1 and 2 leaves without transom

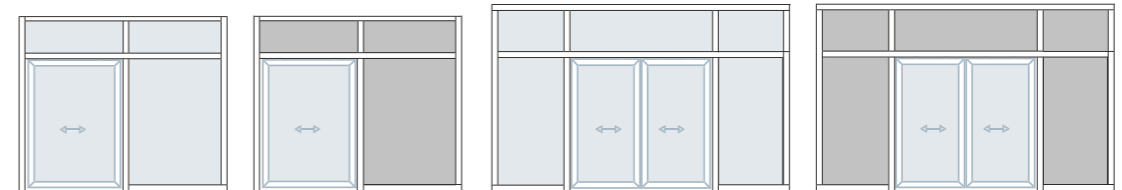

Full-access sliding door  
1 and 2 leaves with transom

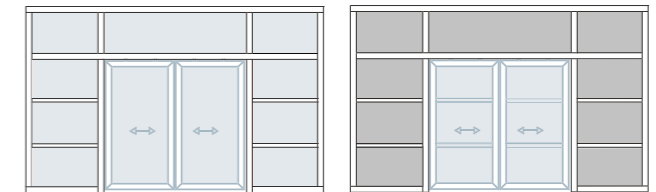



# PERFORMANCE

ACOUSTIC PERFORMANCE		
Type		Certification
Solid moveable partition	39 dB	CER.F.F. C.07-433
Solid moveable partition + door	31 dB	CER.F.F. C.07-433
Full-height glazed partition 44.2	42 dB	CER.F.F. C.07-433
Solid standard partition	42 dB	n°2312.6.575
Solid plaster-coated standard partition	44 dB	n°2312.6.575
Glazed standard partition/2-sided apron wall 44.2	41 dB	n°2312.6.575
Glazed standard partition/1-sided apron wall 44.2	35 dB	n°2312.6.575

MECHANICAL STABILITY		
DURABILITY	Applications	Certification
To a soft body shock (bag of 50 daN with an energy of 120 J applied to the centre of the modules of solid and glazed partitions).		
Shock with sand bag 120 J	Solid modular partition with door	CER.F.F. C.07-433
	Glazed modular partition with door	CER.F.F. C.07-433
To horizontal force (force of 50 daN applied 1.5 m from the ground where the two panels meet)		
Horizontal push 50 kg	Solid modular partition with door	CER.F.F. C.07-433
	Glazed modular partition with door	CER.F.F. C.07-433

SECURITY	Certification
To a soft body shock (bag of 50 daN with an energy of 300 J applied to the centre of the modules of solid and glazed partitions)	CER.F.F. C.07-433
To a soft body shock (bag of 50 daN with an energy of 400 J applied to the centre of the modules of solid and glazed partitions)	European Technical Approval
To a rigid body shock (marble 1 kg, energy of 10 J, imprint < Ø 20, depth < 2 mm)	CER.F.F. C.07-433 / European Technical Approval

MODULARITY	Certification
Modular partition with door: modified installation, interchangeability, tolerance adjustments and adaptation to uneven surfaces	Cer.f.f. C.07-433

MAXIMUM WEIGHT	
Weight per wooden door leaf with split hinges	80 kg
Weight per wooden door leaf with split hinges	40 kg





**Architects:** J-P. Dhalluin & Ph. Peny  
**Photographer:** P. Loubet

#### MATERIALS AND PARTS

As with all Technal systems, only the highest quality materials and components are used to minimise maintenance and ensure long-term performance.

- Aluminium profiles are extruded from alloys 6060 Building compliant with EN 12020, EN 573-3, EN 515 and EN 775-1 to 9.
- Fittings are cast from EN 12844 compliant Zamak 5.
- All gaskets are EPDM or TPE (Thermoplastic elastomer).
- The polyamide thermal breaks are extruded from pA6-6 (0.25 FV).
- Screws are made from stainless steel.

#### FINISHES AND COLOURS

A wide range of finishes and colours is available to meet individual project requirements, enhancing existing buildings and offering architects and designers greater design freedom:

- Natural anodised in accordance with EN 123731: 2001.
- Polyester powder coating finishes in a wide range of colours in accordance with "QUALICOAT".
- OPALE is also available in lacquered finishes with exclusive Technal colours for a stylish and contemporary look.

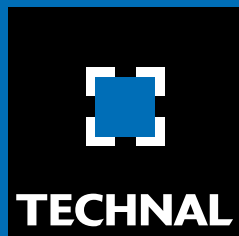

IMAGINE WHAT'S NEXT

270, rue Léon-Joulin  
BP 63709 - 31037 Toulouse cedex 1  
Tél. 05 61 31 28 28 - [www.technal.com](http://www.technal.com)



By  Hydro