

GEODE

CREATIVE CURTAIN
WALL



Architect: Manuelle Gautrand
Photographer: Vincent Fillon

IMAGINE WHAT'S NEXT





GEODE / A COMPLETE CURTAIN WALLING SUITE

GEODE is a comprehensive curtain walling suite offering designers high thermal performance to meet even the most stringent building regulations, and a wide range of aesthetic options based on a single system.

The variety of curtain walling applications, uses the same mullion and transom grid, and enables designers to vary the external appearance of the building envelope whilst benefitting from the design and construction options of a fully integrated system.

WHEN AESTHETICS MEET FUNCTIONALITY

The GEODE system successfully combines the creative and visual demands of architects with the functional needs of contractors, developers and occupiers, by simplifying the technical aspects as well as the manufacturing and the installation processes to ensure optimum quality and cost efficiency.

Designers also benefit from consistent sight lines and interfaces across a project, whether this is full-height, Trame or structurally glazed or features beaded or sloped glazing.

EXCELLENCE IN FAÇADE DESIGN

The GEODE range offers all the inherent qualities of aluminium: aesthetics, durability and low maintenance, and combines innovative technology and construction features with advanced manufacturing techniques for quality installation and long-lasting performance.

This system is the result of Technal's ongoing development programme and has been rigorously tested in accordance with European standards for wind resistance, water tightness, and air permeability.

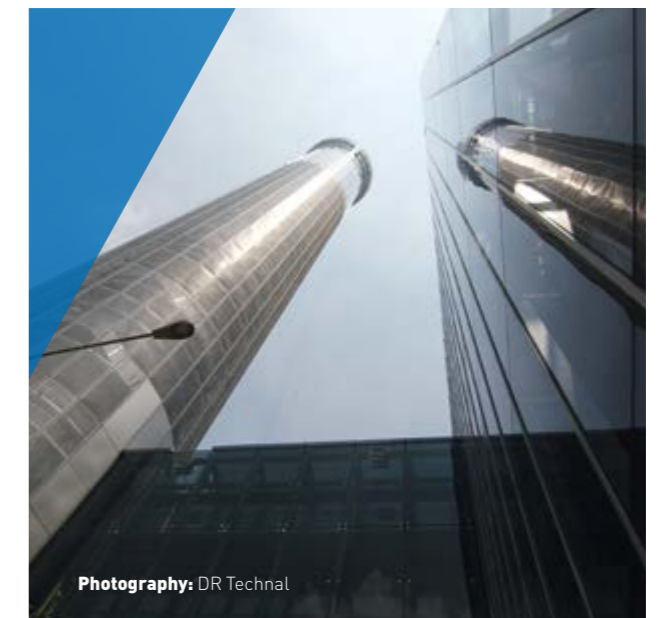

Photography: DR Technal

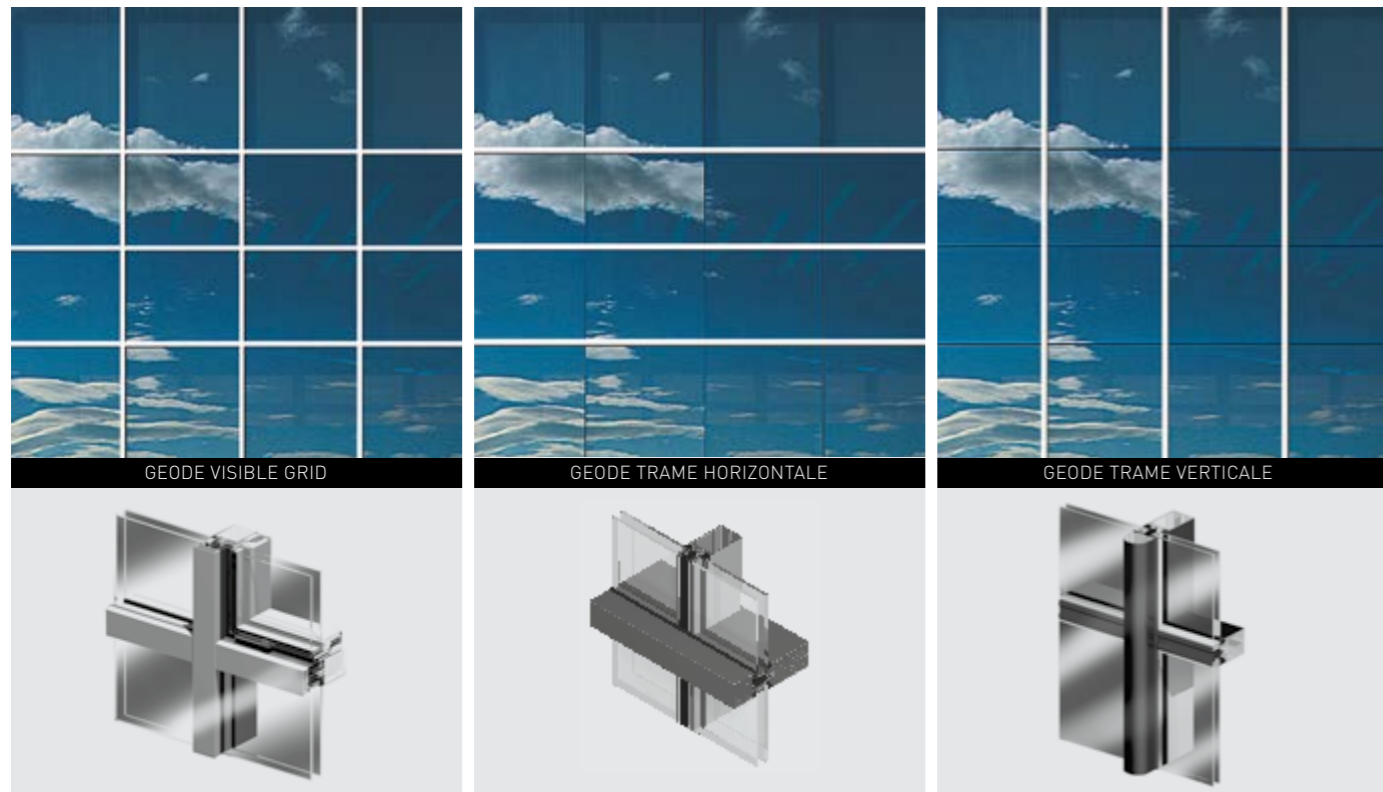

Glazing infill: 6 mm to 42 mm.
Façade: flat or faceted up to 20°.
Concealed opening vent: projecting top-hung, parallel, open-in, tilt-turn, emergency access.

Glazing infill: 6 mm to 42 mm.
Façade: flat or faceted up to 10°.
Concealed opening vent: projecting top-hung, parallel, open-in, tilt-turn, emergency access.

Glazing infill: 6 mm to 32 mm.
Façade: Flat.
Concealed opening vent: projecting top-hung, open-in, tilt-turn, emergency access.

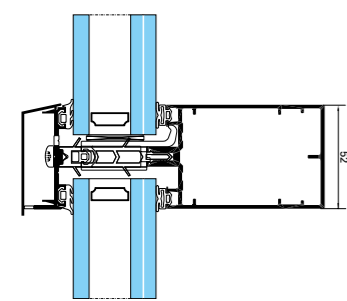

Options:
 - GEODE Acoustic
 - GEODE 62 for large glass units
 - GEODE single glazing from 6 to 11 mm
 - GEODE Flush cap

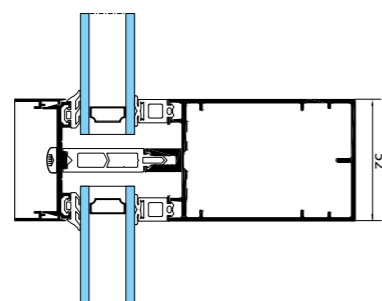

Options:
 - GEODE Acoustic
 - GEODE single glazing from 6 to 11 mm

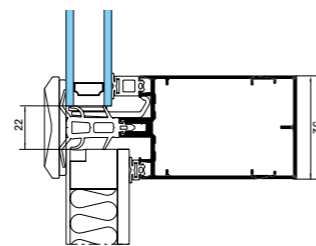

Options:
 - GEODE single glazing from 6 to 11 mm

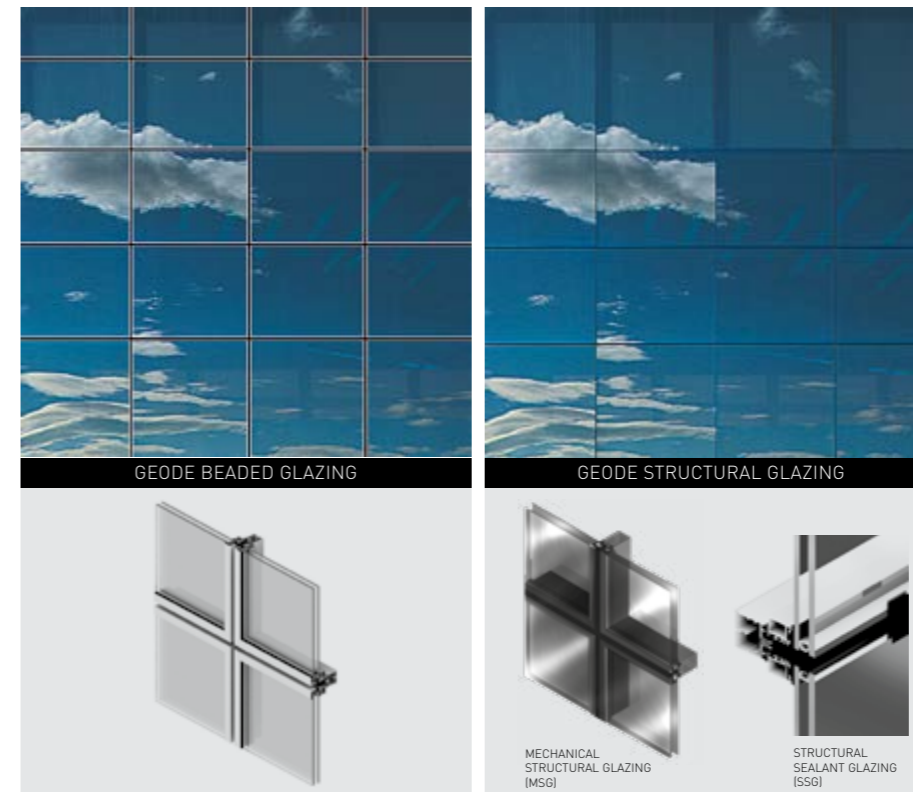

Glazing infill: 30 mm to 36 mm.
Façade: flat or faceted up to 3°.
Concealed opening vent: projecting top-hung, open-in, tilt-turn.

Glazing infill: SSG type 6 mm, 28 mm, 34 mm or MSG from 36 to 46 mm.
Façade: flat or faceted up to 10° (depending on the technology used).
Concealed opening frame: SSG type: top-hung, open-in or tilt-turn. MSG type: top-hung or parallel.

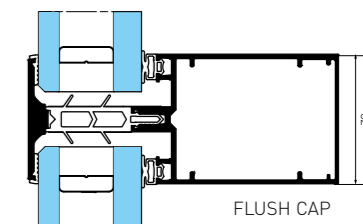
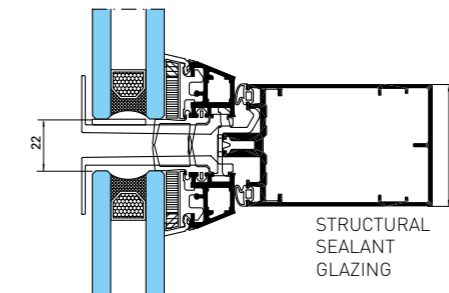
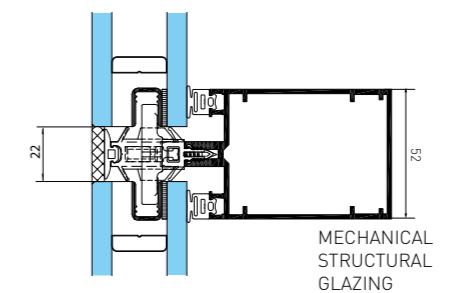
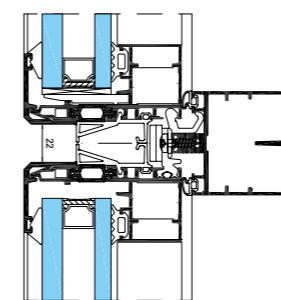

FLUSH CAP

CONTENTS

GEODE DESIGN OPTIONS	8
- VISIBLE GRID	10
OPTIONS:	
- TRAME HORIZONTALE OR VERTICALE	12
- GEODE ACOUSTIC	14
- GEODE 62	16
- GEODE SINGLE GLAZING	18
GEODE BEADED GLAZING	20
GEODE STRUCTURAL GLAZING	24
- MECHANICAL STRUCTURAL GLAZING	26
- STRUCTURAL SEALANT GLAZING	28
- FLUSH CAP	30
GEODE SLOPED GLAZING	32
PERFORMANCE	34

KEY FEATURES AND INNOVATIONS

- **Visual consistency.** Unique aluminium structure for all external appearances. The discreet and consistent 52 mm for the mullions and transoms give a uniform appearance to the entire GEODE range.
- **Thermal efficiency.** The structure's integrated thermal break and the possibility of using the highest performance glazing means that the lowest U_{cW} coefficients can be achieved. Energy consumption for heating, lighting, ventilation and air-conditioning is reduced.
- **Technically advanced frame system.** High-quality components for long-term durability.
- **Intelligent design.** Designed for high-quality manufacturing and installation.
- **Meeting the requirements of each individual project.** We offer a selection of mullions up to 260 mm for structural elements and design flexibility to guarantee cost-effectiveness.
- **Complete system compatibility.** SOLEAL thermal break windows or doors can all be used with GEODE curtain walling for a solution that is tailored to each project.
- **Concealed opening vents.** These opening frame solutions, which preserve the external appearance of the facade, can be used in multiple open-in or open-out applications.
- **Design details.** A wide range of external caps for greater aesthetic choice.
- **Choice of infills.** The system can be used with glass, insulated panels and other types of opaque panels.

CONSTRUCTION

- **Robust construction.** The mullions and transoms are square cut and assembled using a combination of factory-fitted cast face-fixed junction spigots and concealed anti-rotation spigots, or by transom blocks. This strong and easy to build design offers greater accuracy and stability.
- **High-quality design.** The specially designed fittings used for combining mullions/transoms ensure high-quality connections.
- **Cost-effectiveness.** All machining operations can be completed using manufacturing tools in order to reduce manufacturing time and costs, and to achieve consistent quality.

THERMAL PERFORMANCE AND WEATHER TIGHTNESS

- **Increased resistance to climatic conditions.** Fully injectable, the mullion/transom assembly spigot ensures the precise and controlled injection of sealant to ensure weather tightness. In each drainage zone, EPDM caps, positioned between the thermal isolator and pressure plate, prevent the infiltration of water and avoids the need for additional sealant.
- **Effective drainage.** A secondary mullion drainage system enhances weather performance and quality. The system is zone drained and pressure equalised to ensure optimum performance and effective drainage in the most demanding environments.

GEODE
/ DESIGN OPTIONS

GEODE / DESIGN OPTIONS

VISIBLE GRID

FLAT OR FACETED FAÇADES.

Glazing available from 6 mm to 32 mm for flat or faceted curtain wall up to 20°.

OPTIMISED DISTRIBUTION OF LOADS

to prevent unacceptable deflection of the transoms and to allow the use of heavy and large glazing units. Maximum weight of 400 kg [assembled using a connector and anti-rotation spigot].

DESIGN. Choice of aluminium caps to highlight the external design of the façade.

CONCEALED OPENING VENTS.

The projecting top-hung, parallel, tilt-turn or emergency access opening vents provide natural ventilation whilst maintaining the aesthetic lines whatever the appearance of the external façade.

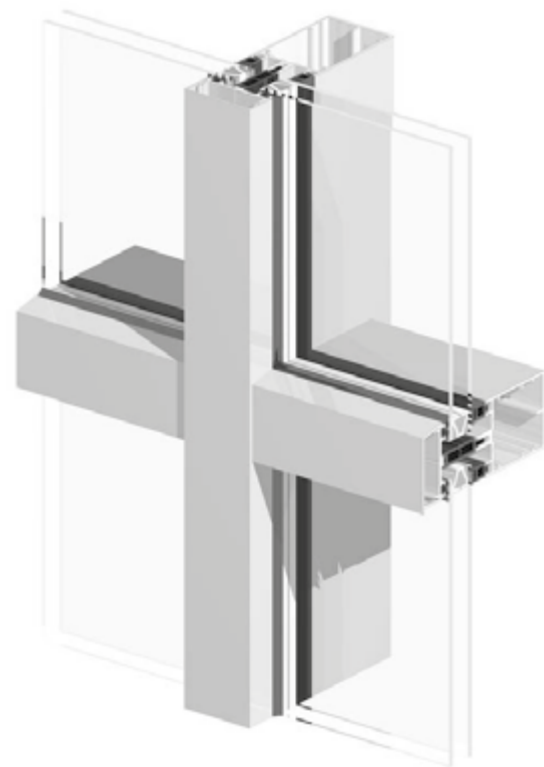

COMMON STRUCTURE WITH 52 MM-MODULE PROFILES.

Range of profile depths: from 4.53 cm⁴ to 2133 cm⁴ to meet the needs of each project.

ADDITIONAL ACOUSTIC AND THERMAL PERFORMANCE.

GEODE Acoustic is an additional option for GEODE Visible grid, developed for projects requiring enhanced acoustic and thermal performances with glazing up to 42 mm.

LARGE DIMENSION GLAZING.

GEODE 62 is an option that uses 62 mm module mullions and transoms to increase the dimensions of the glazing and thus maximising natural light.

INFILLS HELD IN PLACE

with a continuous aluminium pressure plate or a specific polyamide pressure plate with fitted vulcanised gaskets.

CHOICE OF GASKETS.

Available as large vulcanised corner or linear pieces depending on project requirements.

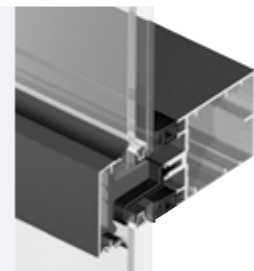
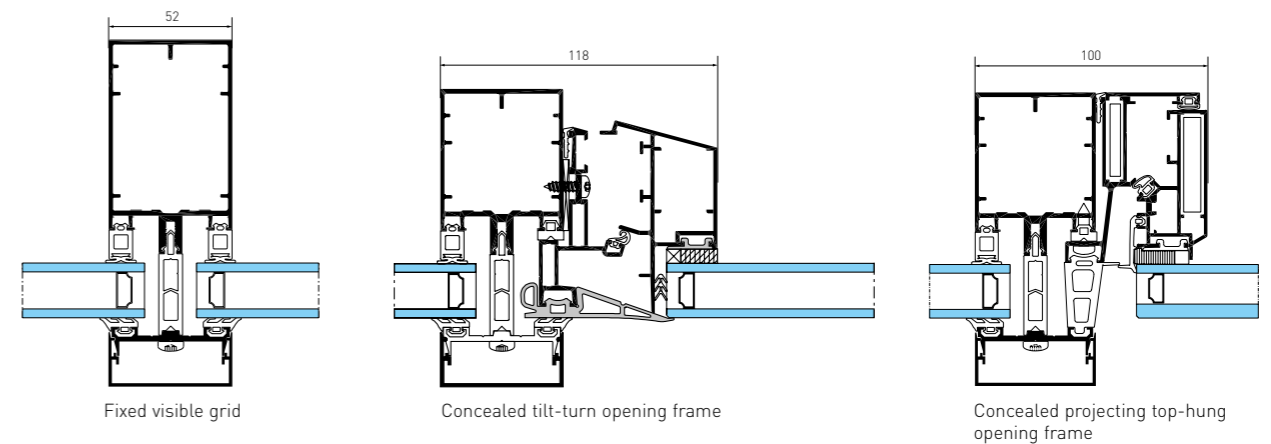

Thermal insulation provided by individual polyamide parts screwed to the mullion-transoms, keeping infills in place and supporting the external clip-on aluminium caps.

Optional non-continuous pressure plate (Technal patent)

Weather tightness assured primarily through the rear face by fitted vulcanised gaskets to accommodate the brise-soleil supports without reducing weather tightness.

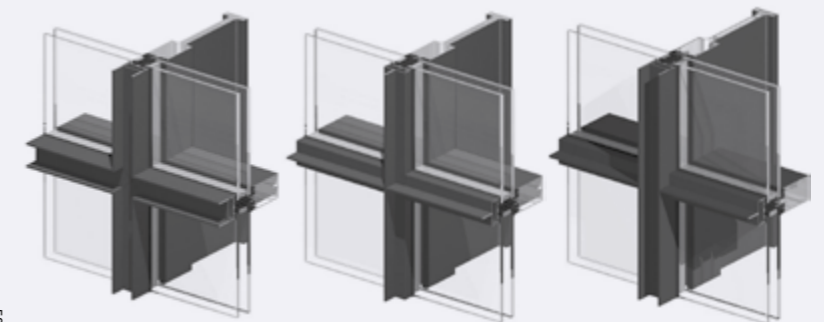
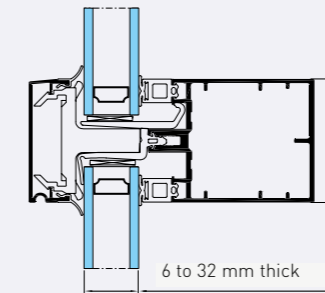

Variety in the appearance of the façade

The range of mullion-transoms and external caps makes it possible to vary the appearance of the façade.

CONSTRUCTION

- **Simplified manufacturing.** The mullions and transoms are straight cut and assembled using a combination of cast spigots face fixed and concealed anti-rotation spigots for ease of manufacture.
- **Faceted façades.** For facets up to ±10°, standard connectors may be used. A transom block combining specially designed pressure plates, caps and adaptors can be used for angles between 10° and 20°.
- **Special option.** The transom assembly block options offers an alternative to anti-rotation spigots in order to meet requirements of design or the project in general.

PERFORMANCE

- **Advanced thermal performance.** The thermal insulation of the standard GEODE visible grid solution is provided via a 34 mm TPE thermal isolator between the pressure plates and the mullion and transom structure. This principle ensures optimal thermal performance and meets or exceeds building regulations' requirements.
- **Thermal insulation** with glazing $U_g = 1.1 \text{ W/m}^2\text{K}$:
 - Fixed curtain wall with 80% glazing (opaque spandrel panel) $U_{CW} = 1.4 \text{ W/m}^2\text{K}$.
 - Fixed curtain walling with 50% glazing (80 mm insulating panel, $U_p = 0.35$) $U_{CW} = 1.1 \text{ W/m}^2\text{K}$.
- **Air, water and wind resistance** in accordance with European and CWCT standards.
- **ITT Testing** and technical approval for the specific pressure plate option.

Thermal calculations of curtain walling carried out in accordance with EN 13947.

GEODE / DESIGN OPTIONS

TRAME (HORIZONTAL OR VERTICALE)

COMMON STRUCTURE WITH 52 MM-THICK PROFILES. Choice of mullion-transoms members from 4.53 cm⁴ to 2133 cm⁴ to meet the needs of each project.

DISTINCTIVE DESIGN DETAILS. GEODE Trame is an additional design option offering the option of highlighting the vertical or horizontal profiles on the building's envelope.

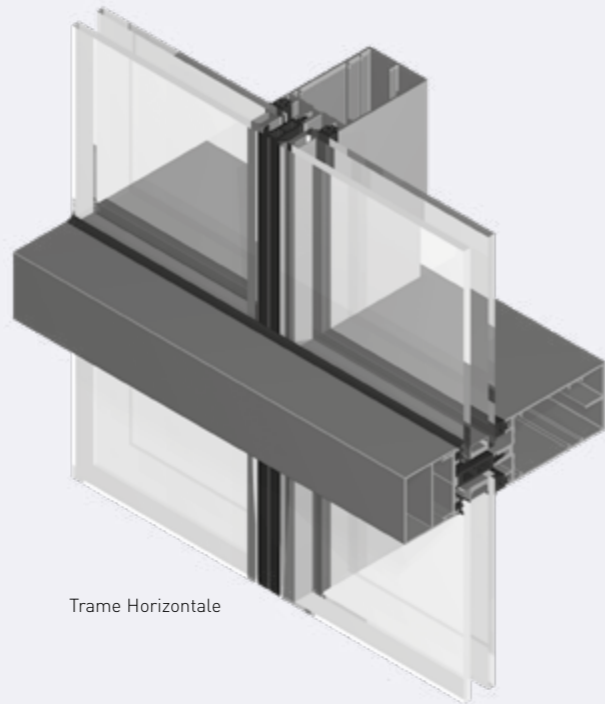

Trame Horizontale

MAXIMUM WEIGHT of 300 kg per transom (assembled using a connector and an anti-rotation spigot).

CONCEALED OPENING VENTS. Projecting top-hung, parallel, tilt/turn and emergency access opening vents provide natural ventilation whilst maintaining consistent sight lines.

MINIMAL STRAIN. On large mullion or transom spans glass deflection is reduced using a special pressure block.

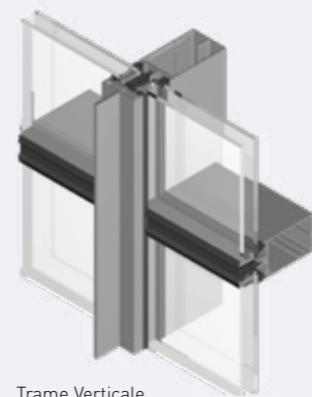

Trame Verticale

GLAZING FROM 6 TO 32 MM. Up to 42 mm for the GEODE Acoustic option.

INFILLS ARE HELD IN PLACE with a continuous aluminium pressure plate, or a specific polyamide pressure plate with fitted vulcanised gaskets, on the transom or mullion.

REINFORCED ACOUSTIC AND THERMAL PROTECTION. GEODE Acoustic is an option designed for the GEODE system. Trame Horizontale for environments requiring heightened thermal and acoustic performance.

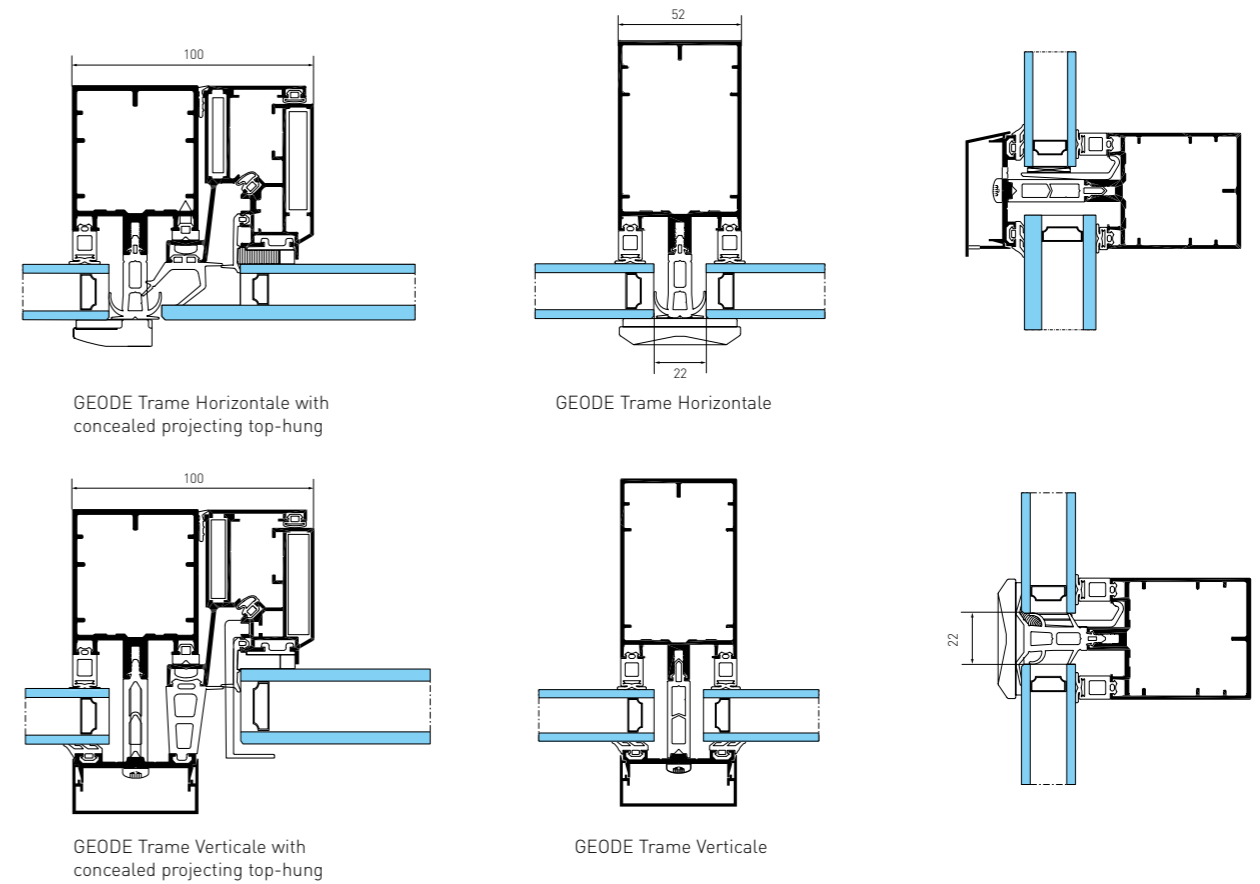

GEODE Trame Horizontale with concealed projecting top-hung

GEODE Trame Horizontale

GEODE Trame Verticale with concealed projecting top-hung

GEODE Trame Verticale

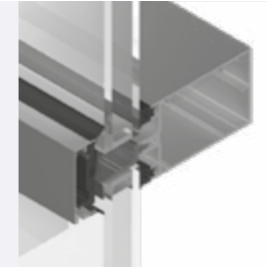

Optional punctual pressure plate (Technal patent) assured primarily through the rear face by fitted vulcanised gaskets to accommodate the brise-soleil supports without reducing the weather tightness.

Horizontal caps clipped on to the special pressure plates and a 22 mm "hollow" effect gasket conceals the verticals. Infills are kept in place horizontally by specific polyamide pressure plates. Special pressure plates keep the panels in place.

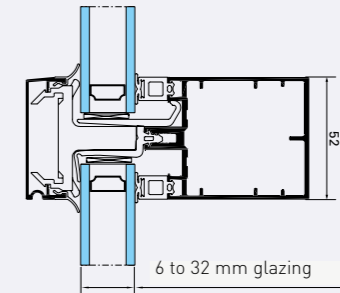

6 to 32 mm glazing

CONSTRUCTION

- **Contemporary design.** Depending on the type of frame, vertical or horizontal, a range of caps add depth to the facade whilst the gaskets, which are flush with the infills, conceal the verticals or horizontal.
- **Dry glazing.** Geode Trame system does not require sealant to be applied on site.
- **Flat or faceted** up to 10° (Trame Horizontale only).

PERFORMANCE

- **Technical design** resistant to the most extreme climatic conditions. A pressure plate on the mullion or the transom, depending on the

version, and a combination of EPDM gaskets keep the infills in place. Effective drainage is ensured by equalising the pressure through holes in the pressure blocks and caps.

- **Thermal efficiency.** GEODE Trame's thermal insulation is assured by a standard 34 mm TPE insulator between the pressure plate and mullion or transom.
- **Thermal insulation** with glazing $U_g = 1.3 \text{ W/m}^2\text{K}$:
 - Fixed curtain wall with 80 % glazing (opaque spandrel panel) $U_{CW} = 1.6 \text{ W/m}^2\text{K}$.
 - Fixed curtain wall with 50% glazing (80 mm insulating panel, $U_{CW} = 0.35$) $U_{CW} = 1.2 \text{ W/m}^2\text{K}$.
- **Air, water and wind resistance** in accordance with European and CWCT standards.
- **ITT testing** and technical approval for the special pressure plate option.

Thermal calculations of facade in accordance with EN 13947.

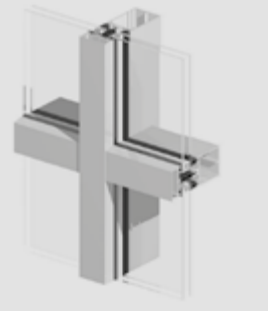

GEODE Acoustic
Visible grid

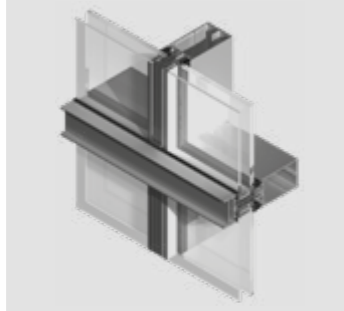

GEODE Acoustic
Trame Horizontale

GEODE / DESIGN OPTIONS ACOUSTIC

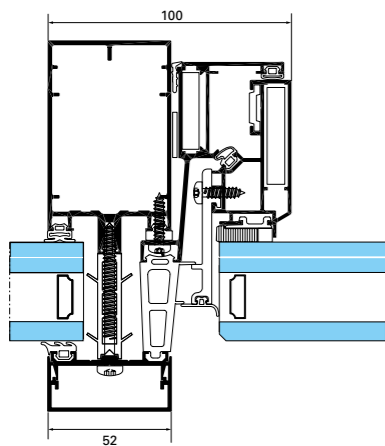

Concealed projecting top-hung
Visible grid

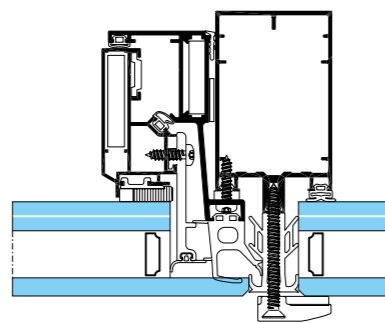

Concealed projecting top-hung,
Trame Horizontale

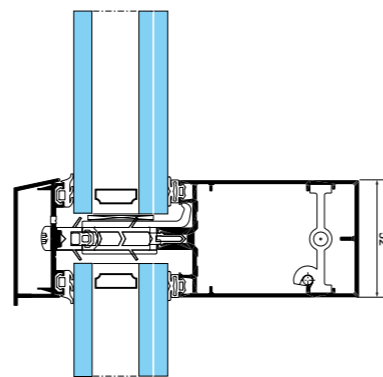

Vertical section
Visible grid or Trame Horizontale

FEATURES

- **The enlarged glazing infill up to 42 mm offers greater acoustic and thermal protection.** Can be used in environments where additional performance is required (city centre apartments, hospitals, buildings close to airports and railways lines, etc.).
- **Visible grid or Trame Horizontale.**
- **Flat or faceted curtain walling.** For visible grid; 10 degrees for Trame
- **Concealed opening vent.** The concealed SSG projecting top-hung opening frames can be supplied for use with 36 mm and 42 mm glazing.
- **System compatibility.** The profiles allow Technal's window and door systems to be integrated into curtain wall structures.

CONSTRUCTION

- The transoms are fixed with spigots or block mounted and can accommodate glazing infill up to a maximum weight of 240 kg per transom.

PERFORMANCE

- **Reinforced thermal insulation** is provided through a multi-chamber spacing gasket and partitioning tabs.
- **Thermal insulation** with 42 mm triple glazing $U_g = 0.6 \text{ W/m}^2\text{K}$:
 - Fixed curtain walling with 80% glazing (opaque spandrels panel) $U_{cw} = 0.9 \text{ W/m}^2\text{K}$.
 - Fixed wall cladding with 50% glazing (80 mm insulating panel, $U_p = 0.35$) $U_{cw} = 0.8 \text{ W/m}^2\text{K}$.
- **Air, water and wind resistance** in accordance with European and CWCT standards.
- **ITT testing.**

Thermal calculations of curtain walling in accordance with EN 13947.

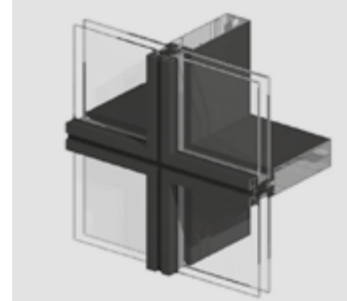
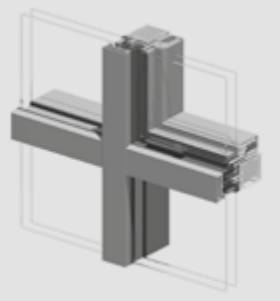

GEODE 62 Visible grid version with external caps

GEODE 62 Visible grid and Trame version

GEODE / DESIGN OPTIONS

GEODE 62

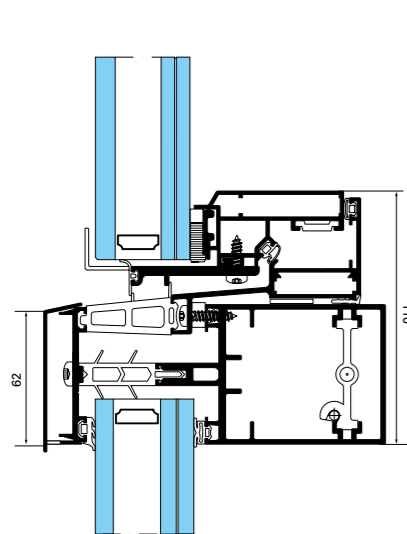

GEODE 62 concealed projecting top-hung

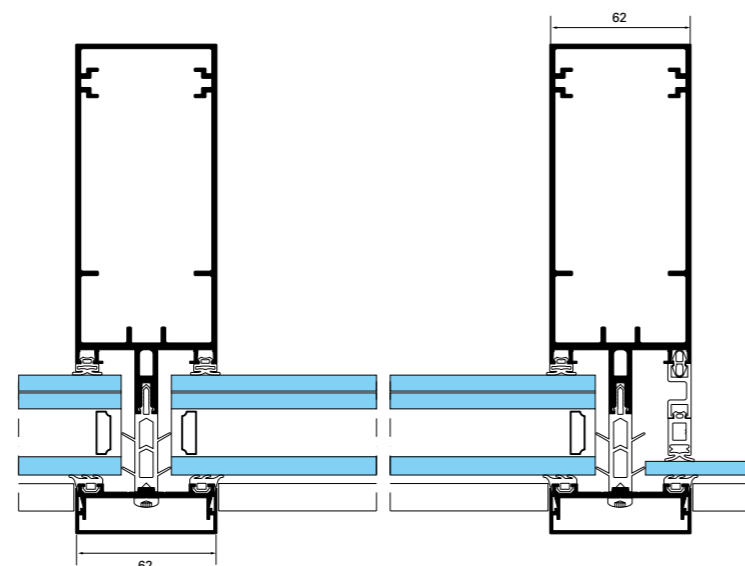

GEODE 62 Visible grid

FEATURES

- **Large dimension glazing.** With larger glass cover of 20mm, GEODE 62 is an option designed for visible grid curtain walling, enabling designers to use large glazing units to create glazed surfaces from 6 to 12 m² (semi-perimeter between 5 and 7 m) and thus to increase the natural light.
- **Load.** The maximum load is 600 kg per transom.
- **Mullions/transoms:** from 80 to 210 mm for inertias from 92 to 1689 cm⁴.
- **Simple application.** For flat façades, this option uses a pressure plate, a horizontal and a vertical cap and can accommodate glazing from 8 mm to 44 mm.
- **Concealed vents.** The concealed projecting top-hung opening vents can be supplied with 36 mm or 42 mm glazing.
- **System compatibility.** The profiles allow Technal's window and door systems to be integrated into the curtain wall grid.

PERFORMANCE

- **Thermal insulation** with 44 mm triple glazing $U_g = 0.6 \text{ W/m}^2\text{K}$:
 - Fixed curtain walling with 80% glazing (spandrels panel) $U_{CW} = 0.9 \text{ W/m}^2\text{K}$.
 - Fixed curtain walling with 50% glazing (80 mm insulating panel, $U_p = 0.35$) $U_{CW} = 0.8 \text{ W/m}^2\text{K}$.
- **Air, water and wind resistance** in accordance with European and CWCT standards.
- **ITT testing.**

Thermal calculations of curtain walling in accordance with EN 13947.



Architect: LA ARCHITECTS
Photographer: LIZ EVE / FOTOHAUS

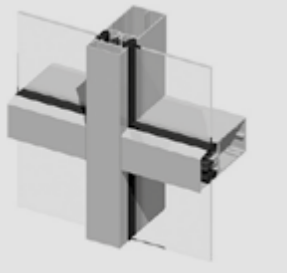

GEODE Visible grid

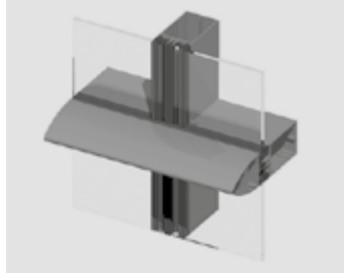

GEODE Trame Horizontale



GEODE Trame Verticale

GEODE / DESIGN OPTIONS SINGLE GLAZING

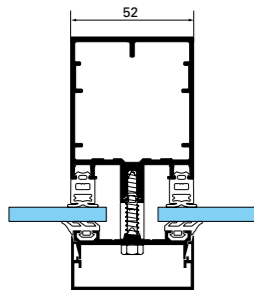

GEODE single glazing
Visible grid

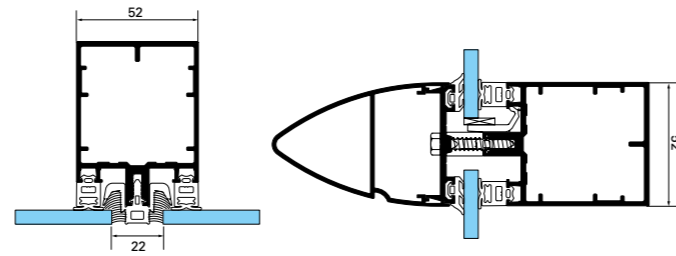
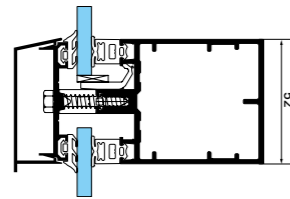

GEODE single glazing
Trame Horizontale

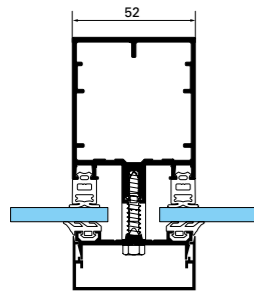

GEODE SG single glazing
Trame Verticale

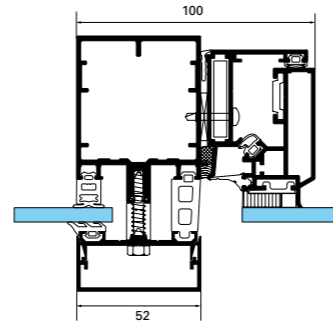
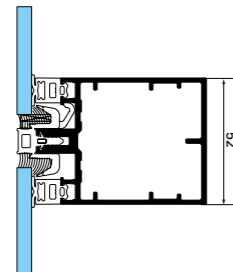

GEODE single glazing with a concealed projecting
top-hung opening frame

FEATURES

- **Version optimised for temperate regions.** The single glazed GEODE option for visible grid and Trame is dedicated to geographical regions in which the climatic conditions do not require advanced thermal performance or the use of double glazing.
- **Concealed vent option.** Structurally bonded projecting top-hung opening vents can be supplied for use with glazing from 6 mm to 11 mm.
- The GEODE single glazing system allows Technal's window and door systems to be integrated into curtain wall structures.
- **Flat and faceted façades:** up to 10°.
- **Laminated single glazing** from 6 to 11 mm.

CONSTRUCTION

- The internal structure and external caps are as used on the standard GEODE visible grid and Trame options.
- Glass deflection can be limited on the free side by a specific piece positioned mid way.

PERFORMANCE

- **Air, water and wind resistance** in accordance with European standards.
- **ITT testing.**

CAPS CHOICE

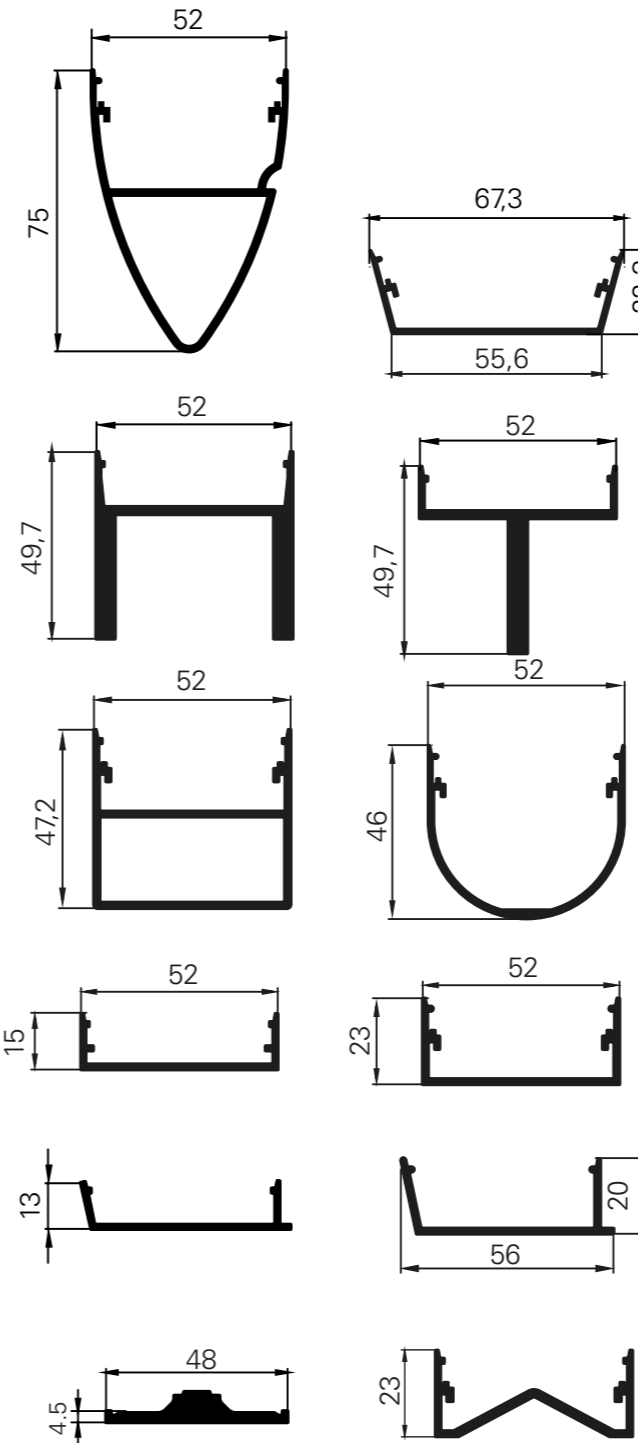

Architects: Paloma Baranguan - Claudia Mayer - LKS Ingemertia
Photographer: Wenzel



GEODE
/ FRAME ASPECT



GEODE / FRAME ASPECT

A CONTEMPORARY ALTERNATIVE.

The external beaded frame option of the GEODE BG system makes it possible to create curtain walling with a "frame" aspect.

INSULATION.

Fixed and opening frames with a thermal break.

CONCEALED OPENING FRAMES.

The concealed projecting top-hung and tilt-turn opening frames, as well as emergency access frames, are available without altering the aesthetics of the façade.

GLAZING FROM THE OUTSIDE.

The top and bottom glazing beads are riveted to the frame to guarantee additional security.

FLAT OR FACETED.

Available as a flat façade or faceted up to $\pm 2^\circ$.

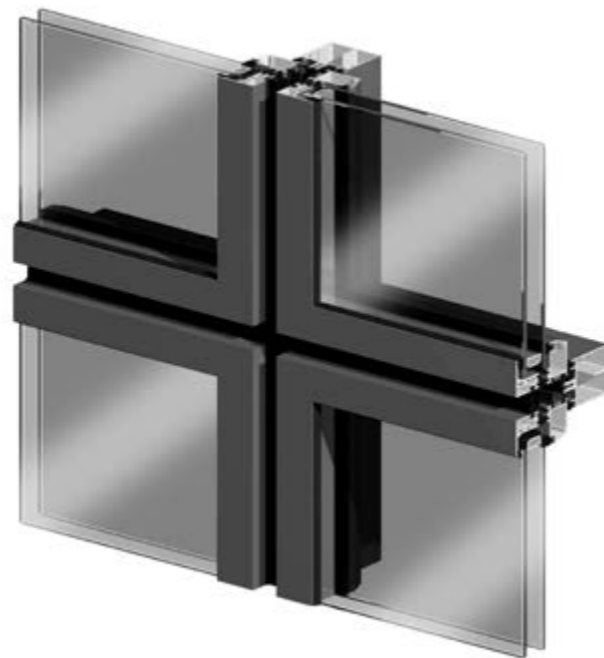

PATENTED TECHNAL DESIGN.

A patented "hook and toggle" fastening system facilitates the installation of the frames.

DRY GLAZING. The glazing is mounted onto the frames in the factory and held in place with beading.

GLAZING AND INFILLS.

GEODE BG can support glazing from 6 mm to 32 mm on the fixed sections and the opening frames.

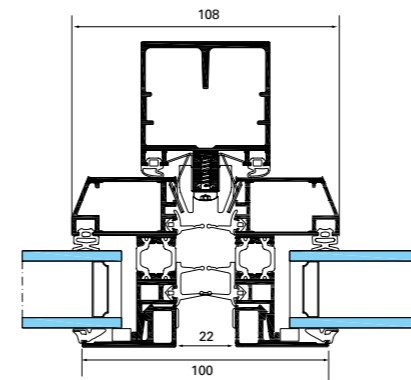

GEODE BG transparent glazing section

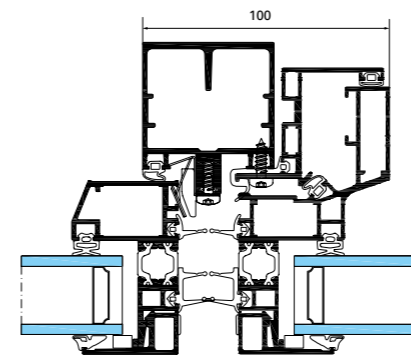

GEODE BG concealed projecting top-hung opening frames

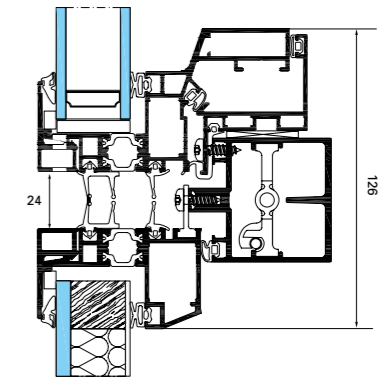

GEODE BG concealed projecting top-hung opening frame

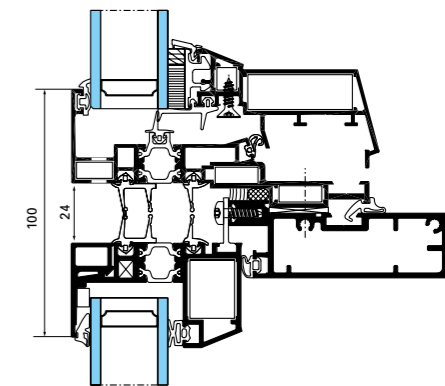

GEODE BG concealed opening frame

CONSTRUCTION

- **Air tightness** . A lower EPDM compression gasket assures the system's total air tightness in the form of vulcanised corners or fitted vulcanised gaskets.
- **Installation.** The carrying frames are fitted to the curtain wall structure with a patented hooking system.

PERFORMANCE

- **Thermal insulation** with glazing $U_g = 1.1 \text{ W/m}^2\text{K}$:
 - Fixed curtain walling with 80% glazing (opaque slab nose) $U_{cw} = 1.5 \text{ W/m}^2\text{K}$
 - Fixed curtain walling with 50% glazing (insulating panel) 80 mm, $U_p=0.35$) $U_{cw} = 1.2 \text{ W/m}^2\text{K}$
- **I.T.T. testing** allows the manufacturer to use CE markings.
- **Air, water and wind** resistant in accordance with European standards

Calculs thermiques des façades réalisés selon EN 13947.

GEODE BG REINFORCED OPTION

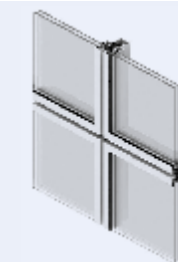

Version adapted to zones with high climatic or environmental requirements.

- Fixed and opening frames with a thermal break.
- **Infills:** Fixed frame up to 200 kg, opening frames up to 120 kg (projecting top-hung) 100 kg (tilt-turn).

- **Concealed opening frame** projecting top-hung or tilt-turn.
- Straight or inclined façades $\pm 3^\circ$.
- **Glazing:** From 30 to 36 mm for fixed frames with transparent glazing and projecting top-hung opening frames, 54 mm insulating panels, tilt-turn opening frame from 28 to 34 mm.
- Thermal insulation up to $U_{cw} = 1.5 \text{ W/m}^2\text{K}$
- Acoustic attenuation up to 40 dB.
- **Air, water and wind resistance** according to European and CWCT standards.
- **Quick installation of frames** using a patented Technal system.

Product available in special conditions.
Contact Technal's engineering department.

GEODE
/ STRUCTURAL
GLAZING



Architect: Juan de Avalos
Photographer: DR Technat

GEODE / STRUCTURAL GLAZING

MECHANICAL STRUCTURAL GLAZING

The **GEODE mechanical structural glazing** curtain walling is a technical design enabling the creation of fully glazed façades without attaching aluminium frames to the glazing. As an alternative to SSG (Structural Sealant Glazing) which uses traditional silicone sealant, the glazing for the fixed and opening sections is attached to the aluminium frame mechanically using special aluminium supports. From the outside, only the glazing and a thin gasket are visible.

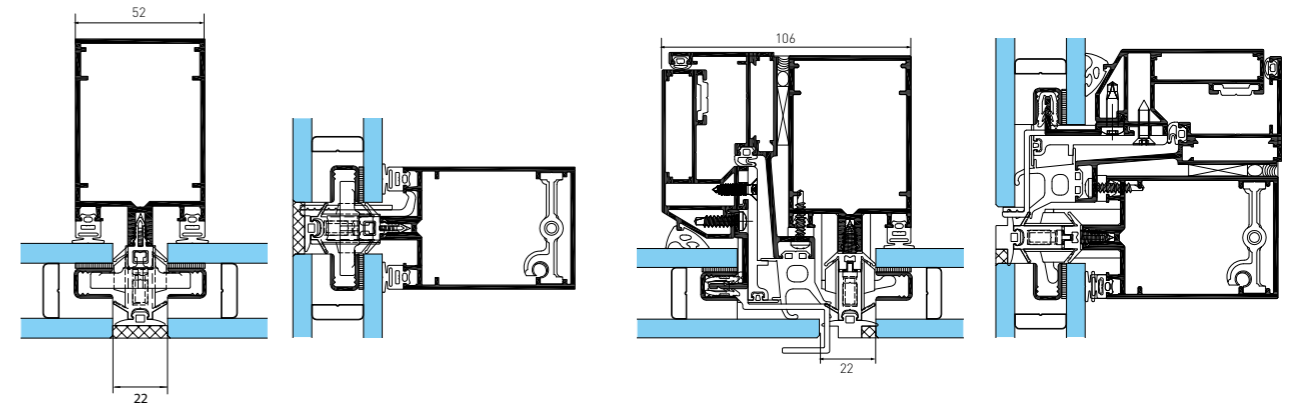

Projecting top-hung or parallel opening

FLAT OR FACETED up to 10 degrees.

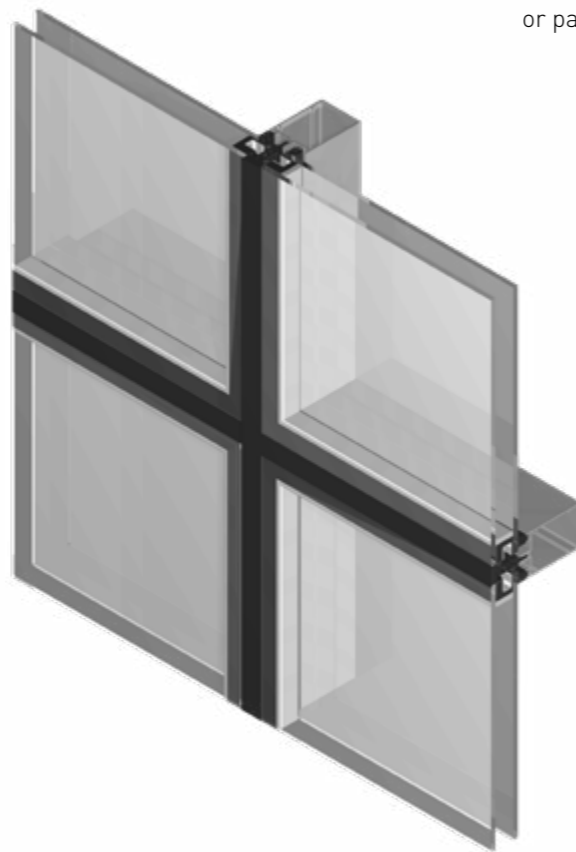

FINISH AND WEATHER TIGHTNESS provided between the glass panel by a dry EPDM or silicone seal.

GLAZING from 36 to 42 mm for the transparent sections of the fixed and opening frames. Spandrel panels with 6 or 8 mm glazing or insulating panels from 40 to 120 mm.

CONCEALED OPENING VENTS projecting top-hung or parallel.

GLASS PANELS:
Fixed frames:
W 3.00 m x H 2.00 m
· Max. weight 240 kg
Vents: projecting top-hung 130 kg
· Parallel 150 kg.

THE GLAZING FOR THE FIXED OR OPENING SECTIONS is attached to and held onto the grid structure by special retaining fixtures made from moulded or extruded aluminium.



Option GEODE SG

- **Glazing and infills.** Fixed and opening frames with glazing from 32 to 34 mm for the transparent spandrel wall panel with glazing from 6 to 8 mm and 4 mm aluminium composite panels for opaque sections.
- **SSG type projecting top-hung opening vent** - max. weight 120 kg.
- **High-performance weather tightness.** A silicone gasket is positioned between the leaves on a continuous support for guaranteed optimal weather tightness.
- **Flat or faceted façade** up to +/- 5°.
- 22 mm gap between the glass panels.

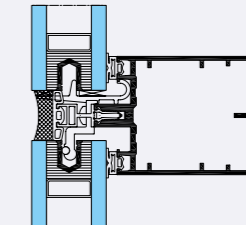

CONSTRUCTION

- **Glass panels**
 - Use of special double glazed unit integrating a continuous u-shaped aluminium profile between the two panes of glass inside the silicone chamber for fixing to the curtain wall structure.
 - The double glazing unit is fixed in place with aluminium toggles positioned at regular intervals along the nose of the aluminium grid structure and screwed into the transoms and mullions.
 - The ends of the toggles are inserted into the u-shaped aluminium profiles between the two panes of double glazing unit.
- **Opening vents**
The concealed opening vents can accommodate projecting top-hung or parallel opening windows. The same double glazing fastening system is used for opening frames. In this case, the glass panels are held onto the opening frame by special aluminium pressure blocks and can accommodate security pieces.

QUICK AND EASY TO MANUFACTURE

- **Reduction of costs and time** in factory and on site:
 - - No aluminium frames to produce and deliver to the glass manufacturer.
 - - No drying/bonding time for the glass panels on the aluminium frames.
- **Glazing** fixed directly onto the curtain wall grid structure without any intermediary profile.

PERFORMANCE

- **Thermal insulation** with glazing $U_g = 1.1 \text{ W/m}^2\text{K}$:
 - Fixed curtain walling with 80 % glazing (opaque border) $U_{CW} = 1.5 \text{ W/m}^2\text{K}$.
 - Fixed curtain walling with 50% glazing (120 mm insulated panel, $U_g = 0.24$) $U_{CW} = 1.1 \text{ W/m}^2\text{K}$.
- **Air, water and wind resistance** in accordance with European and CWCT standards.
- System subject to a **DTA [French technical application document] and ITT testing** allowing the manufacturer to use CE markings.

GEODE / STRUCTURAL GLAZING STRUCTURAL SEALANT GLAZING (SSG)

LESS VISIBLE ALUMINIUM. The GEODE SSG systems meets the demand for glazed façades with a smooth finish and no externally visible aluminium. The glazing units panels are bonded onto the carrier frames with silicone.

QUALITY ASSURANCE. The system is manufactured and bonded in the factory by certified companies in accordance with European standards.

CONCEALED OPENING VENTS. Concealed projecting top-hung and tilt-turn opening vents up to 120 kg are available and ensure the consistent appearance of the façade.

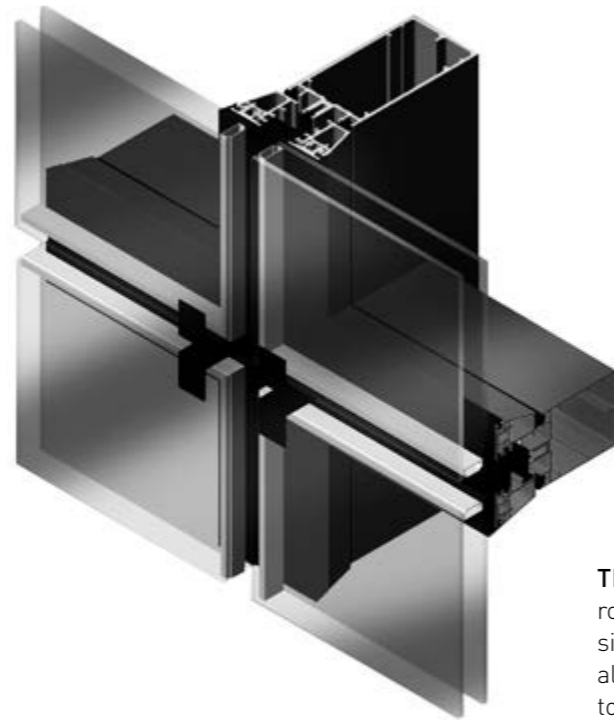

PATENTED DESIGN. A patented hanging system facilitates onsite installation.

FLAT OR FACETED FAÇADE up to $\pm 2^\circ$.

SHADOW GASKETS OF 22 MM BETWEEN GLAZED PANELS.

LOADS. The glazing is supported by a glass security support at each corner of the aluminium support frame. Each fixed frame can therefore receive glass with a maximum weight of 80 kg.

GLAZING AND INFILLS. The GEODE SSG system can receive 6 mm glazing in front of the opaque sections, 23 mm or 31 mm for insulating glazing or insulating panels of 60 mm.

THE SSG GLAZING, with rounded edges on all four sides are offset at the top to allow water to drain away and to improve performance.

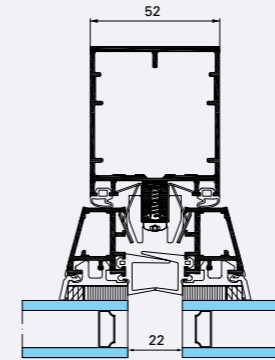

GEODE SSG fixed frame

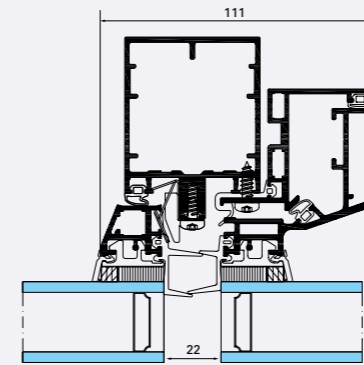
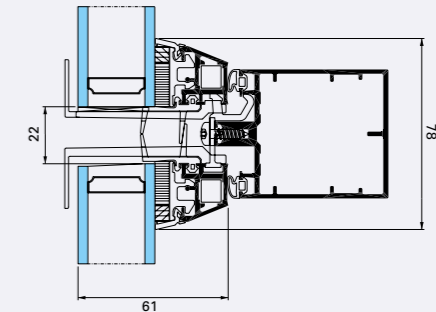

GEODE SSG concealed projecting top-hung opening frame

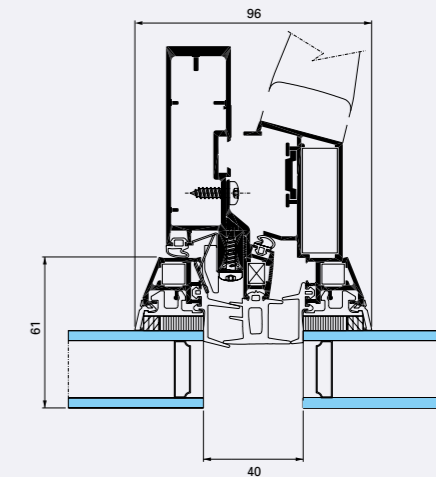

GEODE SSG concealed tilt-turn opening frame

CONSTRUCTION

- **Air tightness.** An internal EPDM compression gasket assures the system's total air tightness in the form of vulcanised corners or fitted vulcanised frame gaskets.
- **Quick installation.** The SSG frames are installed onto the curtain wall grid with a patented hooking system.

PERFORMANCE

- **Thermal insulation** with glazing $U_g = 1.1 \text{ W/m}^2\text{K}$:
 - Fixed curtain walling with 80% glazing (opaque slab nose) $U_{cw} = 1.8 \text{ W/m}^2\text{K}$
 - Fixed wall cladding with 50% glazing (insulating panel) 50 mm, $U_p = 0.54$ $U_{cw} = 1.8 \text{ W/m}^2\text{K}$
- SSG subjected to **ATE and I.T.T testing** allowing the manufacturer to use CE markings
- **Air, water and wind** resistant in accordance with European standards.

GEODE REINFORCED SSG OPTION



Version adapted to zones with high climatic or environmental requirements.

- Fixed frames up to 200 kg, opening frames up to 120 kg.
- **Projecting top-hung opening frame**
- Flat or faceted façades $\pm 3^\circ$.
- **Glazing:** of 6, 28 and 34 mm for the transparent section, 54 mm

insulating panels, 28 and 34 mm opening frames.

- **Thermal insulation** reinforced up to $U_{cw} = 1.6 \text{ W/m}^2\text{K}$
- Acoustic attenuation up to 40 dB.
- **Air, water and wind resistance** according to European and CWCT standards.
- **Quick installation of frames** using a Technal patented system.

Product available in special conditions. Contact Technal's engineering department.

Thermal calculations of wall cladding carried out according to EN 13947.

GEODE / STRUCTURAL GLAZING FLUSH CAP

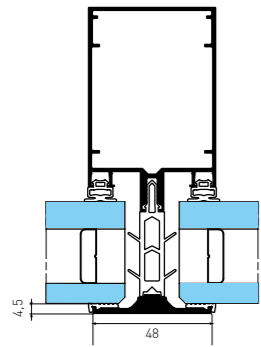

Fixed frame

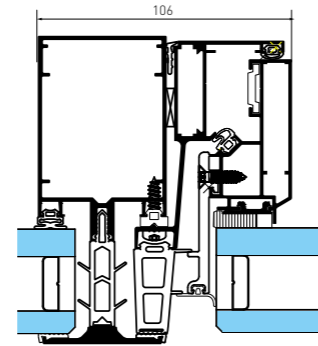
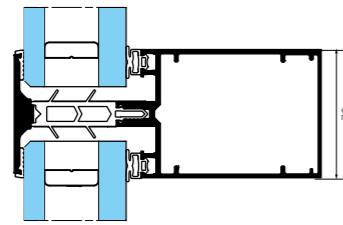

Top-hung open-out vent

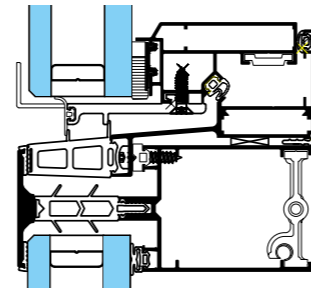

GEODE Flush Cap is an **aesthetic and economical alternative** to structural glazing options, which allows a flush appearance across the facade.



FEATURES

- Black integrated cap-pressure plate 4.5-mm depth on the external glazing
- **Infill up to 42 mm**
- **Vertical façade**
- Convex/concave facet 90° to 135°
- **Concealed vent**, 24- or 31-mm glazing
- **SOLEAL Visible vents** (with fireman's access)
- Maximum weight: 300Kg by glazing panel
- Possibility to realise an all glass facade with horizontal or vertical outline.

PERFORMANCES

- **ITT tests** allow CE marking
- **Weather tightness** in accordance with European standards



Photographer: P.Loubet



FEATURES

Uniform appearance. These solutions offer designers the possibility to create inclined roofs, vaults, atria and pyramids that are fully compatible and visually consistent with GEODE vertical façade.

GEODE Visible grid:
Specially designed cap. A special cap for the horizontal and vertical sections reduces the accumulation of water on the inclined sections.

GEODE Trame Verticale:
Minimal strain. The vertical caps and a silicone seal with pressure blocks on the transoms prevent deflection of the glass under negative wind pressure.

Glazing. The double glazed units are manufactured using structural silicone.

Incline. Minimum slope: 5° for double glazing (with CSTB technical approval).

CONSTRUCTION

- The 8 mm to 32 mm infills are held in place with horizontal and vertical pressure plates for the GEODE Visible grid system and by vertical pressure plates and horizontal pressure blocks for the GEODE Trame Verticale.
- Design details. The rafters and transoms are square cut and assembled using the penetrating transom principle.

PERFORMANCE

- Effective drainage. Drainage takes place at the end of the transoms via the rafters.
- Resistance to climatic conditions. The weather tightness of the grid system is assured via an internal EPDM gasket and external butyl tape. The weather tightness of the GEODE Trame Verticale for the Visible Grid version is assured by EPDM gaskets and a silicone gasket on the transoms.

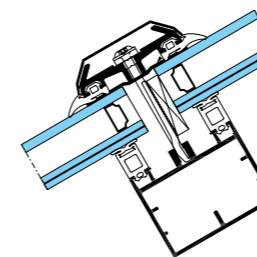
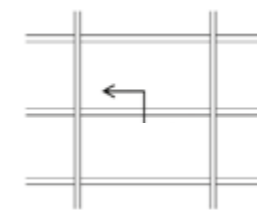

GEODE Sloped, Visible Grid

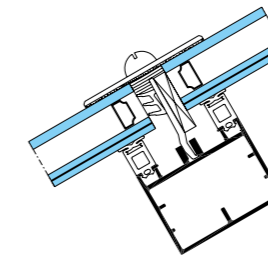
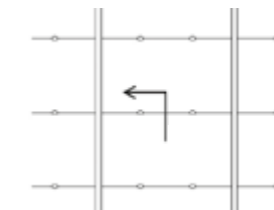

GEODE Sloped with Trame Verticale

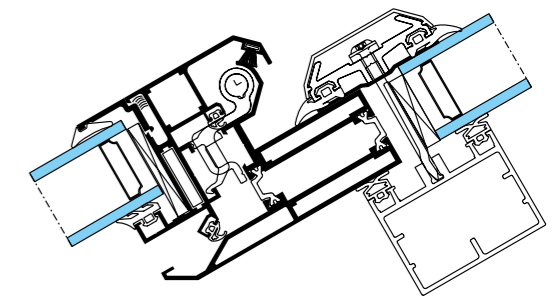

GEODE Roof-mounted opening vent

APPLICATIONS

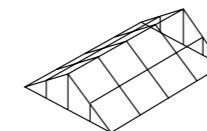

Lantern

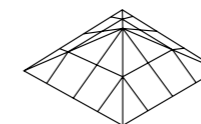

Pyramid

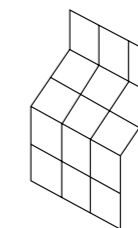

Roof light

PERFORMANCE

WEATHER PERFORMANCE

A sample curtain wall has been tested for each of the following systems in accordance with NF standards (French standard), meeting the specific curtain wall requirements of the European standard EN 13830. The GEODE range also meets the requirements of the CWCT standard for building envelopes. Further information is available upon request.

		GEODE	Perméabilité à l'air	Étanchéité à l'eau	Résistance à la pression du vent
FRAME	VISIBLE GRID	FIXED	A4	R7	Résultats satisfaisants en pression et dépression 1600Pa et 2400Pa (pression brusque)
		PROJECTING TOP-HUNG OPENING	A3	E1200	VC5
	TRAME HORIZONTALE	FIXED	A4	R7	Résultats satisfaisants en pression et dépression 1600Pa et 2400Pa (pression brusque)
		PROJECTING TOP-HUNG OPENING	A4	E9A	VC3
	TRAME VERTICALE	FIXED	A4	R7	Résultats satisfaisants en pression et dépression 1600Pa et 2400Pa (pression brusque)
		PROJECTING TOP-HUNG OPENING	A4	E8A	VC3
	ACOUSTIC	VISIBLE GRID	A4	E1200	Résultats satisfaisants en pression et dépression 1600Pa et 2400Pa (pression brusque)
		HORIZONTALE TRAME	A4	E750	Résultats satisfaisants en pression et dépression 1600Pa et 1800Pa (pression brusque)
		PROJECTING TOP-HUNG OPENING	A4	E1050	VC3
	GEODE 62	VISIBLE GRID	A4	R7	Résultats satisfaisants en pression et dépression 1600Pa et 2400Pa (pression brusque)
		PROJECTING TOP-HUNG OPENING	A4	E1050	VC3
	SINGLE GLAZING	VISIBLE GRID	AE	RE1650	Résultats satisfaisants en pression et dépression 800Pa et 1200Pa (pression brusque)
HORIZONTALE TRAME		AE	RE900	Résultats satisfaisants en pression et dépression 800Pa et 1200Pa (pression brusque)	
PROJECTING TOP-HUNG OPENING		A4	E1200	VC2	
BEADED	BEADED GLAZING	FIXED	A4	R7	Résultats satisfaisants en pression et dépression 1600Pa et 2400Pa (pression brusque)
		PROJECTING TOP-HUNG OPENING	A4	E9A	VC3
REINFORCED BEADED GLAZING	FIXED	A4	R7	Résultats satisfaisants en pression et dépression 2400Pa et 3600Pa (pression brusque)	
	PROJECTING TOP-HUNG OPENING	A4	R7	Résultats satisfaisants en pression et dépression 1600Pa et 2400Pa (pression brusque)	
STRUCTURAL GLAZING	MECHANICAL STRUCTURAL GLAZING	FIXED	A4	R7	Résultats satisfaisants en pression et dépression 1600Pa et 2400Pa (pression brusque)
		PROJECTING TOP-HUNG OPENING	A4	E1200	VC3
	STRUCTURAL GLAZING SG VERSION	FIXED	A4	E1200	Résultats satisfaisants en pression et dépression 2500Pa
	SSG	FIXED	A4	R7	Résultats satisfaisants en pression et dépression 1600Pa et 2400Pa (pression brusque)
		PROJECTING TOP-HUNG OPENING TILT & TURN	A4	E9A	VC3
	REINFORCED SSG	FIXED	A4	R7	Résultats satisfaisants en pression et dépression 2400Pa et 3600Pa (pression brusque)
	CAPOT PLAT	FIXED	A4	RE1200	Résultats satisfaisants en pression et dépression 2400Pa et 3600Pa (pression brusque)
PROJECTING TOP-HUNG OPENING		A4	E1200	VC3	

THERMAL PERFORMANCE

The precise performance depends on a combination of the size of the frames, the thickness of the glass, the type of infill and the options chosen. The values below are provided for indicative purposes only. Further information is available upon request.

U_{cw} coefficient of curtain walling without protection (W/m².K)

		U _g insulation coefficient of glazing (W/m².K)										
		Triple glazing			Double glazing							
		0.6 + int. insulating	0.6	0.8	1.0 + int. insulating	1.1 + int. insulating	1.0	1.1	1.3	1.5	1.7	1.9
FRAME	Grid				1.2	1.3	1.3	1.4	1.5	1.6	1.8	1.9
	Grid v. Acoustic	0.9	1.0	1.1	1.2	1.3	1.3	1.4	1.5	1.6	1.8	1.9
	Horizontale				1.2	1.3	1.3	1.4	1.5	1.6	1.8	1.9
	Horizontale v. Acoustic	0.9	1.0	1.1	1.2	1.3	1.3	1.4	1.5	1.6	1.8	1.9
	62 Grid	0.9	1.0	1.1	1.2	1.3	1.3	1.4	1.5	1.6	1.8	1.9
STRUCTURAL GLAZING	MSG*				1.4	1.5	1.5	1.6	1.7	1.8	2.0	2.1
	SSG				1.7	1.8	1.8	1.8	2.0	2.1	2.2	2.4
	Reinforced SSG version							1.8	1.9	2.1	2.3	2.4
BEADED	Beaded glazing				1.4	1.5	1.5	1.6	1.7	1.8	1.9	2.1
	Reinforced BG version							1.7	1.9	2.1	2.2	2.4

* insulator ACERMI 40 mm (U_p = 0.66)

100% glazed on the inside: transparent glazed section + opaque spandrel panel
2 frames per level:
W = 1.35 m x H spandrel = 0.70 m + transparent glazing = 2.50 m.
insulating, extruded polystyrene, 50 mm thick (U_p = 0.54)

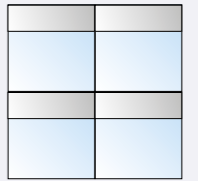

U_{cw} coefficient of curtain walling without protection (W/m².K)

		U _g insulation coefficient of glazing (W/m².K)										
		Triple glazing			Double glazing							
		0.6 + int. insulating	0.6	0.8	1.0 + int. insulating	1.1 + int. insulating	1.0	1.1	1.3	1.5	1.7	1.9
FRAME	Grid				1.1	1.1	1.1	1.2	1.3	1.3	1.4	1.5
	Grid v. Acoustic	0.9	1.0	1.0	1.1	1.1	1.1	1.2	1.3	1.3	1.4	1.5
	Horizontale				1.1	1.2	1.2	1.2	1.3	1.4	1.5	1.6
	Horizontale v. Acoustic	0.9	1.0	1.1	1.1	1.1	1.2	1.2	1.3	1.4	1.4	1.5
	62 Grid	0.9	1.0	1.1	1.1	1.1	1.1	1.2	1.3	1.3	1.4	1.5
STRUCTURAL GLAZING	MSG*				1.3	1.4	1.4	1.4	1.5	1.6	1.7	1.7
	SSG				1.7	1.8	1.8	1.8	1.9	2.0	2.1	2.1
	Reinforced SSG version							1.6	1.7	1.8	1.9	2.0
BEADED	Beaded glazing				1.4	1.4	1.4	1.4	1.5	1.6	1.7	1.7
	Reinforced BG version							1.5	1.6	1.7	1.8	1.8

* insulator ACERMI 40 mm (U_p = 0.66)

60% glazed on the inside: glazed transparent section + opaque curtain wall
2 frames per level
W = 1.35 m x H transparent glazing = 1.50 m + curtain wall = 1.00 m. 50 mm thick extruded polystyrene insulator (U_p = 0.54)

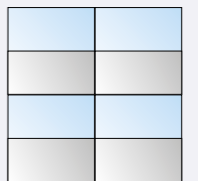

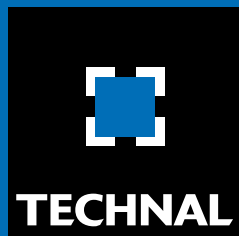

IMAGINE WHAT'S NEXT

270, rue Léon-Joulin
BP 63709 - 31037 Toulouse cedex 1
Tél. 05 61 31 28 28 - www.technal.com



By  Hydro