

# SAPA DOOR DESIGN GUIDE

COMBINE FUNCTION AND DESIGN



**sapa:**

By  Hydro



# Openness and transparency

Our door systems offer transparency and create a sense of openness. Practical solutions let in more daylight, make orientation easier and are more welcoming.

Sapa Building Systems in aluminium ensure minimal maintenance and reliable operation, which is appreciated by property owners and residents alike.

Our systems offer many design possibilities and are compatible with most applications and architectural solutions. We have doors to suit every space.

**Benefits of aluminium.** We have chosen a selection of fittings in aluminium that create an integrated look. We show most solutions with natural anodised door leafs, as this finish shows off aluminium at its best and has good resistance to wear. Door leafs and frames in contrasting finishes or colours can be used to highlight doors and bring the architecture into focus.

These aspects are naturally unique to every project.

Our building system for doors covers a wide range of applications and allows the incorporation of various functions. Our door solutions are suitable for offices, hospitals, schools and universities, residential buildings, industry, administration premises, sports halls, exhibition halls, arenas and shopping centres.

**Exterior.** Design entrances, glazed elements, windows and facades using our easy-to-combine systems. Entrances can easily be enhanced by adding our profile for access control, entry phone systems and electronics. A durable profile with a

service cover conceals all wiring and attachments. The service cover simplifies installation, servicing and maintenance, while also protecting electronics from tampering or damage.

**Interior.** Doors and glazed elements that open into different spaces can share the same character despite having very different requirements. In many spaces it is an advantage if the choice of materials, design and finish can be harmonised.

**Dimensions.** We do not have any modular size restrictions.

**Tailor to your requirements** regarding protection and safety, fire and evacuation, free opening dimensions, stability, fittings, infill panels, glass, etc.

**Set the tone** by selecting profiles, finish, fittings, proportions and materials, including glass or infill panels, etc.

**Door systems are ideally suited for:**

- entrances
- goods in/out and passageways
- storerooms, bicycle rooms, refuse rooms and laundry rooms
- toilets, wash rooms and nursery rooms
- fire-resistant doors
- burglar-resistant doors

# Design guide entrances

Make entrances clear by using colours, design, patterns on glass and through choice of materials. Careful design makes orientation easier and makes a building more welcoming. Transparency at the entrance is important for security.

## Sustainability

**Choose the right door system.** Four systems with narrow and modular profiles.

**Door stop.** Must be fitted at BOTH bottom and top of door. Door closers and automation do NOT replace door stops.

**Hinges.** Choose from universal, concealed or lap butt hinges. Select the number of hinges to suit the weight, width and application. For example, in a school it is advisable to fit three hinges even to smaller, lightweight doors. Universal hinges are the strongest choice. Concealed hinges allow a larger opening and cleaner design. Lap butt hinges are a neat and proven solution.

**Natural anodised door leaf, rebate section and reinforced rebate section.**

For increased durability.

**Replaceable rebate section and reinforced rebate section.** Make repairs easier.

---

## Accessibility

Consider placement of handles, control devices, etc. Doors should be easy to open.

**Visual markings, warning markings.** The glass must be clearly visible and show up against the background.

**Contrasting finishes.** Give the entrance visual clarity. The handle, frame or door leaf can be made to contrast with the wall, to aid orientation.

**Free opening.** The free opening must be adequate in size.

**Anti-finger trap devices.** Anti-finger trap devices are available for all systems.

**Door sill.** The choice of door sill is important for accessibility. Various types are available. Doors without door sills naturally offer the best accessibility.

---

## Security

**Transparency and good lighting** are clearly important when planning a secure environment.

**Entry phone and access control system.** Increase security for users and visitors. An E-frame is a practical solution that can be used with both insulated and uninsulated systems.

**Lock in frame.** Reduces risk of trapping.

**Choice of glass.** The function and performance of the glass are critical for the overall effect.

---

## Design

**Function and appearance.** Our building systems give a great freedom in design.

**Choice of system and profiles.** The building system benefits from a massive range of possibilities.

**Colours and surface finishes.** Our products can be finished by powder coating in NCS-S and RAL colours or anodising. Consider hinges, door closers and handles when choosing colours.

**Glass.** Use patterns and transparency, screen printing, print or foils. Glass offers fantastic design opportunities.



Entrance with entry phone/access control system. Door 2060 with frames 3050, in clear anodised finish. Glass with screen printing.

# Controlling channelled traffic

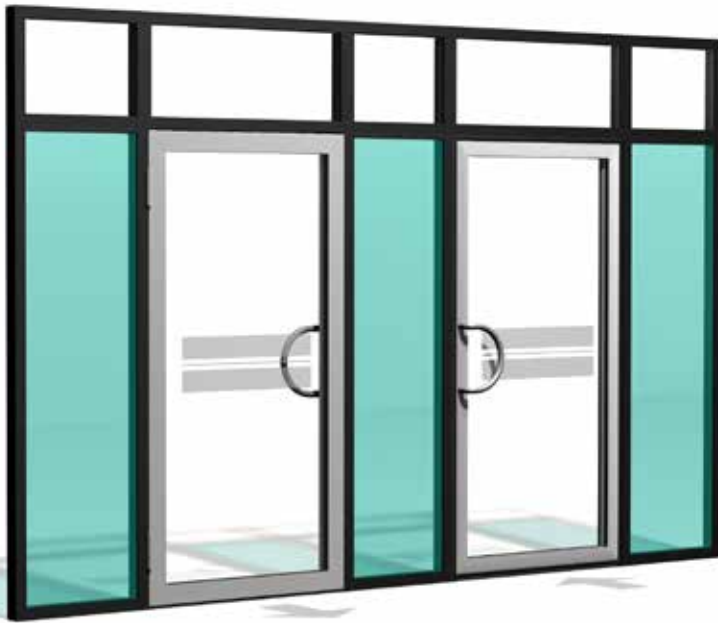

## Entrance with channelled traffic

- Single doors in fixed elements provide stability and functionality.
- Entrance control.
- Can be combined with a profile housing access control system.

*Door in clear anodised finish with powder coated frames and glazing bars.*



## Double doors

- Double doors with single active door. Large opening for moving goods in and out.
- Emergency exit fitted with emergency or panic fittings.
- Alternatively, two active doors for channelled traffic.
- Can be combined with a profile housing access control system.

*Door, frames and glazing bars in clear anodised finish.*

## Combination possibilities

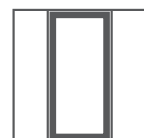

# Show off or create privacy



## Store entrance

- Single doors in fixed elements provide stability.
- Recommended solution for stores with products on show.
- Can be combined with a profile housing access control system.

*Door 2060 in clear anodised finish, frames 4150 powder coated.*



Entrance with **infill** panel as privacy screen.

*Door, clear anodised door leaf and powder coated frame.*



Entrance with **partial privacy** screening on glass.

*Door, clear anodised door leaf and powder coated frame.*



Entrance with top light, side light and centre bar.

*Door, frame and glazing bars in clear anodised finish.*

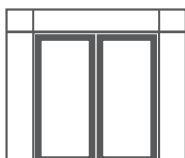
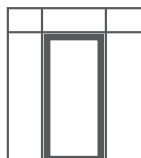

# Designing internal doors



**Glass.** Use screen-printed glass, patterned glass or tinted glass.

*Door 2050, clear anodised, with powder coated frame.*



**Infill panel.** Use aluminium sheet, wood veneer, laminate, or even rubber or checker plate.

*Door 2050, clear anodised, with powder coated frame.*

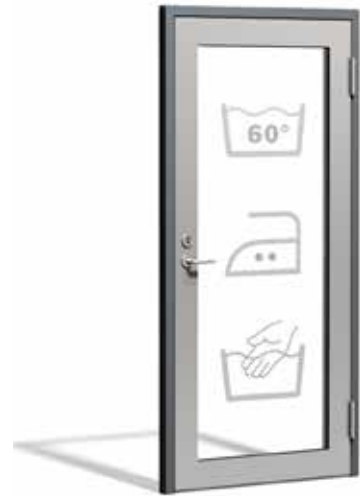

**Information.** Doors that bear their own clear message make navigation easier.

*Door 2050, clear anodised, with powder coated frame.*



**Door 2060.** A bevelled glazing bead creates a shadow edge. Asymmetrically installed glass.



**Door 2050.** Door leaf with flat surface. Asymmetrically installed glass.



**Door 2050.** Door leaf with flat surface, door with glazing bars. Asymmetrically installed glass.

Combination possibilities, door with top light and side light. Door 2050/2060 and side light in 3050/4150

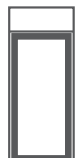





**Side lights and top lights.** Gives a clear view and allows communication between rooms. Add an automatic door opener for easy entry, and a profile containing an access control system.



Add feature glass for special requirements, such as privacy protection or safety.

*Figures 1 and 2: door 2050, frame 3050, in clear anodised finish.*



**Door 2050** with L-shaped glazing bead 68717. Symmetrically installed glass.



**Door 2050** with bevelled glazing bead 68729. Symmetrically installed glass.



**Door 2050** with rectangular glazing bead 68730. Symmetrically installed glass.

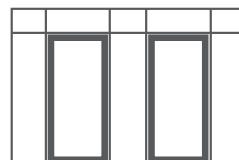
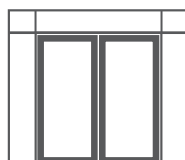
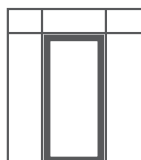
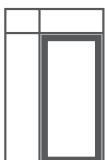

# Design elements

## Door leaf profiles for asymmetrically installed glazing units with integrated glazing bead



**Door 2060.** A bevelled glazing bead creates a shadow edge.

*Photo shows narrow profile.*



**Door 2050 and 2086.**

Door profile with flat surface, integrated glazing bead.

*Photo shows narrow profile.*



**Replaceable rebate section and reinforced rebate.**

Natural anodised finish is recommended for visual integrity.



**Door 2060.**

Integrated glazing bead.



**Door 2050.**

Integrated glazing bead.

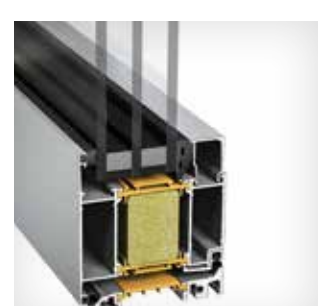

**Door 2086 SX Plus.**

Integrated glazing bead.



**Door 2086 SX Plus.**

Integrated glazing bead.

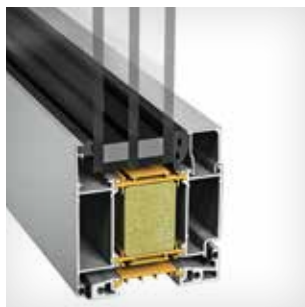

**Dörr 2086 Extreme.**

Integrated glazing bead.



**E-frame for door 2086.**

Profile for electronics.

**Door leaf profiles with glazing beads for symmetrically installed glazing units**



Door 2050/2086 with **L-shaped glazing bead.**



Door 2050/2086 with **bevelled glazing bead.**



Door 2050/2086 with **rectangular glazing bead.**



Door 2050 with **L-shaped glazing bead.**



Door 2050 with **bevelled glazing bead.**



Door 2050 with **rectangular glazing bead.**

**Aluminium hinges**



**Universal hinge.**



**Lap butt hinge.**



**Concealed hinge.**  
Only for door 2086.

# Accessibility – designing for everyone

Accessibility – general: Doors must be designed to be opened, accessed and closed by people who use wheelchairs and walking aids. People who have difficulty orienting themselves should also be able to find their way to doors easily. In practice, this means that:

- the free opening should be adequate in size
- the opening should have no door sill or should have a low, ramped door sill
- doors should be easy to open
- sensors should be used to prevent the doors from closing on someone or trapping them
- the space around the doors and the controls for opening and closing doors should be designed for use by people in wheelchairs
- doors should be in contrasting colours so that they can be seen
- door handles that contain nickel should be avoided.

In general, simplicity and clarity are key features to aid orientation.

Provide plenty of space,  
position controls clearly  
and make orientation easy.

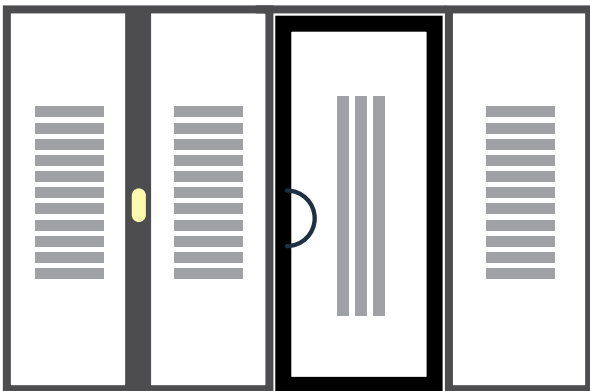

Control for door opener, installed in E-frame/E-profile.  
Illustration shows glass with screen printing or foil.

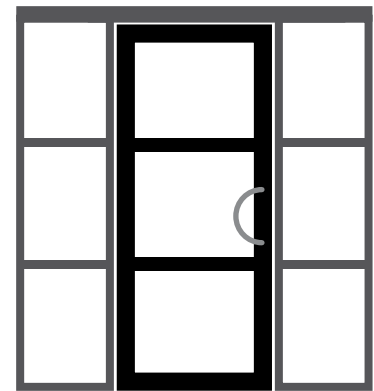

Example of contrasting finish to door and glazing bars, to make orientation easier.

## Accessibility, recommendations

Handisam has compiled detailed information on points to consider for making doors accessible.

**Automation.** Heavy doors, such as doors fitted with door closers, should be fitted with automatic door openers. Use safety sensors to reduce the risk of trapping.

**Warning markings.** Contrast level of 0.40 on NCS scale. One solution is two sets of markings at heights of 1.5 m and 0.9 m. Markings must be clearly visible.

**Contrasting finishes.** Contrast-marking makes orientation easier for people with impaired vision. Brightness contrast should be at least 0.40 on the NCS scale. Warning markings must also contrast clearly with the background and work in different light conditions.

**Free passage dimensions.** Entrance doors: Handisam recommends 84 cm for entrance doors. Swedish building regulations from Boverket state at least 80 cm.

Door sill. Where possible, doors should have no door sill. If a door sill is essential, the following may be a solution: as low a door sill as possible, preferably lower than 1.5 cm, and ramped with a slope of no more than 1:12. Alternatively a rubber door sill, strip door sill or brush door sill may be used.

Source: Accessible doors – detailed guidelines from Handisam  
Read more about accessibility in the Boverket publication "Enklare utan hinder" or Handisam's "Tillgängliga dörrar-Handisams fördjupningsblad" (in Swedish).

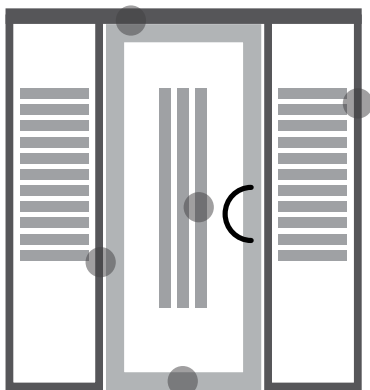

<b>Function</b>	More information on our website
<b>Free opening</b>	Options and design formulas are given in this section. <i>See the relevant Door.</i>
<b>Anti-trap devices</b>	There are various solutions, anti-trap devices are available for all systems. <i>See the relevant Door.</i>
<b>Automation</b>	Designed to suit the application and customer's special requirements. <i>See the relevant automation supplier.</i> Special profiles are available to conceal automation equipment. <i>See the relevant Door.</i>
<b>Door sill</b>	Various types are available. <i>See the relevant Door.</i>
<b>E-frame</b>	Available for all doors. Note positioning of E-frame. <i>See E-frame, Doors.</i>
<b>Contrasting finishes</b>	NCS-S and RAL-scale powder coatings or anodising. <i>See Surface Finishes.</i>

Space required around a CONTROL DEVICE according to Handisam's "Accessible doors" recommendations.

- Controls for door openers (including card readers, code locks, entry phones etc., that are linked to automatic door openers) should be placed at least 70 centimetres but preferably no more than 1 metre from a corner or other obstacle, and at least 1 metre from the front edge of a swing door when it is open, to minimise the risk of someone being struck by the door when it opens.
- Other controls near doors should also be placed at least 70 centimetres and preferably 1 metre from a

corner or other obstacle. All controls that are used at the same time must be placed close to each other. An existing call button for a lift that is positioned 50 centimetres from a corner is acceptable. (Lift standard EN 81-70:2003 specifies that a call button should be placed at least 50 centimetres from a corner.)

If there is a guide route to the door, it must lead to the controls, even if they are positioned 70 centimetres from the front edge of the door.

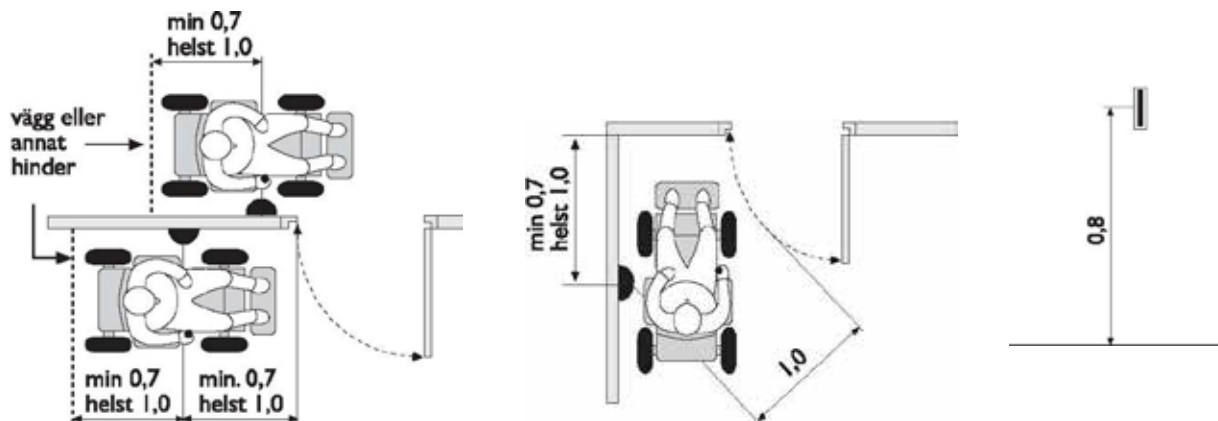

Illustrations: Fotoskrift AB (based on information from Handisam).

# Design guide fittings

## Fittings, form and function

Design the entire solution. Our system solutions offer many different possible combinations. A selection is shown below. Choose from a range of materials and finishes. Door systems, hinges and handles create a harmonious look. Door closers can be colour-coordinated with frames. Clear anodising ensures good durability and preserves the sensation of metal, giving an impression of stability and permanence.



2086/2050 narrow profile, outside.

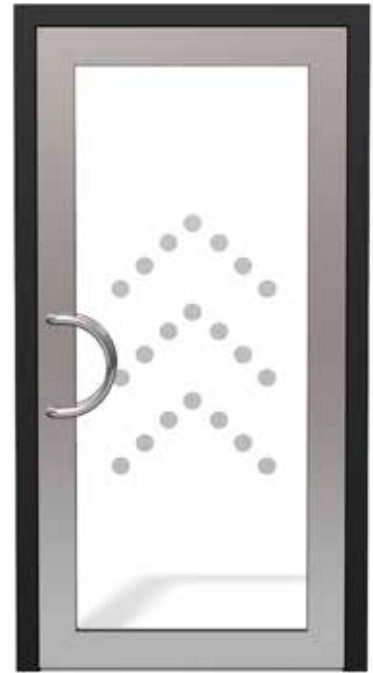

2086/2050 modular profile, outside.



**Semicircular handle** with concealed attachments. Height 300 mm, Ø 30 mm. Aluminum or stainless steel.



**Triangular handle** with concealed attachments. Height 300 mm, Ø 30 mm. Aluminum.



**Offset handle** with concealed attachments. Height 300 mm, Ø 30 mm. Aluminum.



**Lever handle for inner door.** Lever handle, knob, rosette and cylinder rosette with modular profile. Width 137 mm, Ø 21 mm.



**Lock installed in frame.** Eliminates trapping risk when using knob. Makes wiring of electric lock easier.



**Lock installed in door leaf.** Door leaf profiles for modular lock.

# Sapa door closers

## Door closer with standard arm or sliding rail



**Sapa door closer with standard arm, DCS500.**

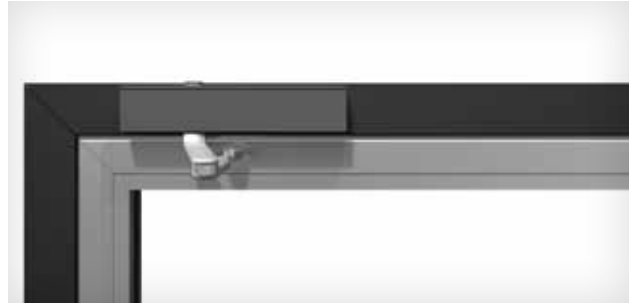

**Choice of door closers with arm.** Fit products from your chosen supplier if desired.



**Sapa door closer with sliding rail, DCG800.**



**Choice of sliding rail door closers.** Fit products from your chosen supplier if desired.

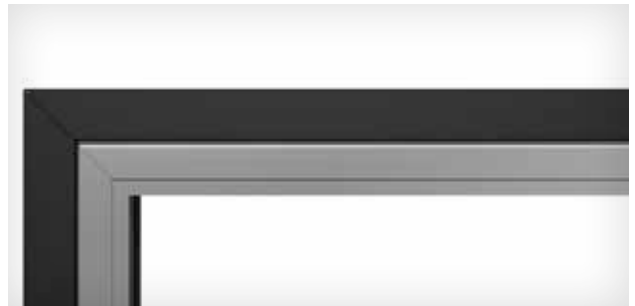

**Built-in concealed door closer.** Fit products from your chosen supplier if desired.

## Automatic opening/closing for swing doors

*Doors that open and close automatically are recommended for accessibility, and to improve access and convenience at heavily trafficked entrances. Protection from the wind is often important for comfort. In many cases channelling of traffic is recommended, to separate the entrance from the exit.*

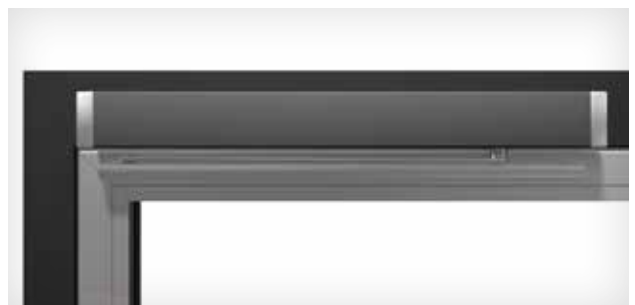

**Automatic door opener.** Fit products from your chosen supplier if desired.

# Sapa door closer

## With standard arm - DCS500

DCS500 Adjustable closing force 1–5 tested according to EN 1154 A for door widths up to 1250 mm. Latching function and closing speed are infinitely adjustable. Constant damping force. Same version fits left and right sides.

Built-in depth just 41 mm. Weight: 1280 g. Door opening angle: max. 180°. Approved for fire and smoke doors.

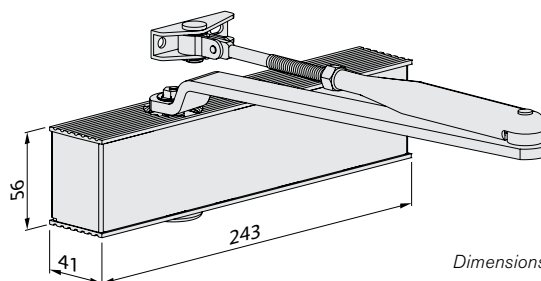

Dimensions: DCS500, 1-5

Door leaf installation on hinge side.  
Frame installation on rebate side.

## With sliding rail - DCG800

DCG800 adjustable closing force 2–5 tested according to EN 1154 A for door widths up to 1250 mm. Latching function, closing speed and damping on opening are infinitely adjustable. Same version fits left and right sides.

Built-in depth with fixing plate, just 49 mm. Door opening angle: max. 180°. Approved for fire and smoke doors.

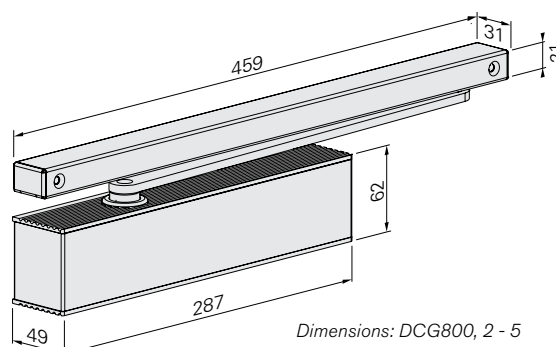

Dimensions: DCG800, 2 - 5



# Sapa door closer

## Performance and functions

Sapa Building Systems' door closers are manufactured using a quality process that is certified to ISO 9001.

All versions of door closers can be combined with fire doors and smoke doors – and are tested in accordance with EN 1154 A.

All products are tested in compliance with the relevant EU directives and are CE marked.

		DCS500	DCG800
Closing force (adjustable)	Size	1 - 5	2 - 5
Door width	≤1250 (mm)	▪	▪
Dimensions (including fixing plate)	Length (mm)	243	287
	Depth (mm)	41	49
	Height (mm)	56	62
Fixing plate (according to EN 1154 A)		▪	▪
Hinge side and rebate side		▪	▪
Left/right		▪	▪
Latching action (adjustable)		▪	▪
Closing speed (adjustable)		▪	▪
Damping when opening		constant *	adjustable
Tested according to EN 1154 A		EN 1154A	EN 1154A
Approved for fire and smoke doors		<b>F</b>	<b>F</b>
Marking		<b>CE</b>	<b>CE</b>

\*= NOTE! Function only available when installed on the hinge side.

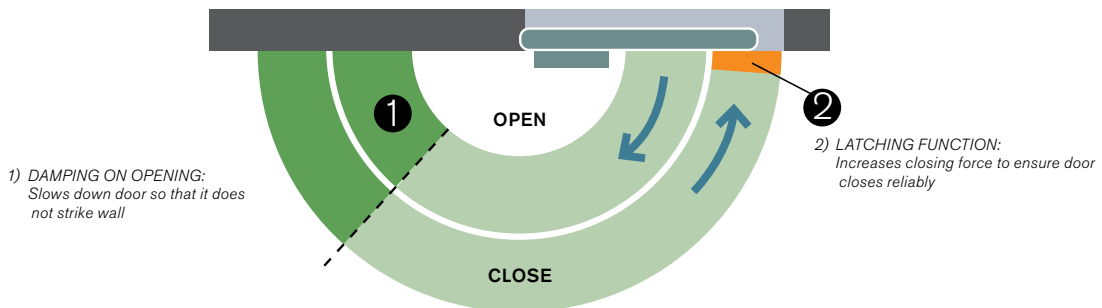

### Closing speed

The door closing speed is measured from the point the door starts to close to a few centimetres before the latching point. The last few centimetres of the closing action are controlled by the latching valve.

### 1 Damping when opening

Reduces the opening speed and prevents a door from being blown open by the wind. This reduces the risk of damage to the door and adjacent wall.

### 2 Latching function

The latching zone is the last few centimetres before the door is latched. An adjustable latching speed allows the speed to be increased to overcome the resistance of door seals, door locks and rising air pressure, for example.

You can find more door closers on our website

[www.sapa.it](http://www.sapa.it)

Damping on opening does not replace a door stop!

We always recommend fitting door stops to our doors to ensure safe operation.

# Painting according to NCS-S and RAL

Sapa works with many popular paint types: textured, metallic and clear coatings, in addition to the standard powder coating. Polyester powder is used for powder coating. There are effectively no limits on colour choice for painting. We can offer all the colours covered by the NCS-S and RAL colour scales.



# Colour range anodising



*Clear anodising Na- 20 my*



*Sepia Hx-5*



*Champagne Hx-10*



*Light Amber Hx-20*



*Amber Hx-30*



*Dark Amber Hx-40*



*Black Hx-50*



*Gold GD-30*



*HM White*



*Stainless look*



*Brushed look*

*The printed patterns/colours may not be reproduced accurately here. Please contact Architect Support for samples*

# Entrances



*Dockan block, Malmö, Sweden*



*Swedbank, Örnsköldsvik, Sweden*



*Restaurant Sjön, Jönköping, Sweden*



*Finspång Arena, Sweden*



*Clarion Hotel & Conference, Trondheim, Norway*



*KappAhl, Gothenburg, Sweden*



*Drammensbadet, Norway*



*Karpus II, Kongsberg, Norway*

# Sapa E-karm for integrated electronics

Entry phones, access control systems, cameras, locks and connectors are some common examples of components fitted to modern entrances. Our E-frame profile simplifies the wiring, installation and servicing of electronic components. A service cover creates a neat appearance and discourages tampering. The E-frame profile lets you combine functionality, safety, security and clean design. E-frames are available for Sapa Doors 2050, 2060 and 2086.

Smart features give reassurance. An effective and practical entrance has to be welcoming as well as safe and secure.



*E-frame 2086: Inside, with service cover open*



*Entrance with entry phone/access control system. Door in natural anodised finish with powder coated frames. Lock installed in frame. Reinforced rebate section.*

# Sapa Door systems overview



Sapa Door Systems	2086 / 2086 SX			2050	2060
	Std	Plus	Extreme	Standard	Standard
System specifications					
Door types					
Swing doors	▪	▪	▪	▪	▪
Double doors/Meeting doors	▪	▪		▪	▪
Sliding door/Auto sliding door				▪	
<b>Design glazing bead, symmetrically installed glass</b>					
Bevelled, L-shape, Rectangular	▪			▪	
<b>E-frame for integrated electronics</b>					
E-frame	E-frame 2086			E-frame 2050	E-frame 2050
<b>Section depth</b>					
Narrow section	89 mm			89 mm	78 mm
Modular section	120 mm			120 mm	120 mm
<b>Glass/infill choice, asymmetrically installed glass</b>					
Glass thickness	20-64 mm			3-33 mm	3-33 mm
Infill panel	▪			▪	▪
<b>Glass/infill choice, symmetrically installed glass*</b>					
Glass thickness	32-42 mm			5-10 mm	
<b>Performance</b>					
System specification	Std	Plus	Extreme	Std	Std
Airtightness acc. to EN 12207	n/a	2	4	n/a	n/a
Watertightness acc. to EN 12208	n/a	4A	9A	n/a	n/a
Resistance to wind load acc. to EN 12210	n/a	C2	C3	n/a	n/a
Anti-finger trap device**	▪			▪	▪
Replaceable rebate sections	frame side only			frame side only	▪
Burglar resistance acc. to EN 1627	available in class RC2-RC3				available in class RC2-RC3
Fire resistance, see website	EI 30			E 30	E 30-EI 30
<b>Facade system/Glazed elements</b>					
Facade 4150, 4150 SX	▪				▪
Facade 4150 PH	▪				
Facade 4150 SSG	▪				
Facade 5050 SG	▪				▪
Glazed elements 3050				▪	▪
Glazed elements 3086	▪				

Sliding-, window- and folding doors, see website, Sliding Doors.

\* For performance of doors with symmetrically installed glass, see website.

\*\* 2086: Anti-finger trap device has various designs depending on chosen system specification.

**sapa:**

By  **Hydro**

## Hydro Building Systems, region North

### Sweden

SE-574 81 Vetlanda  
T +46 (0)383 942 00  
E [sapa.se@hydro.com](mailto:sapa.se@hydro.com)

### Norway

NO-2027 Kjeller  
T +47 63 89 21 00  
E [sapa.no@hydro.com](mailto:sapa.no@hydro.com)

### Denmark

DK-8240 Risskov  
T +45 8616 0019  
E [sapa.dk@hydro.com](mailto:sapa.dk@hydro.com)

### Finland

FI-02180 Espoo  
T +358 (0)9 867 82 80  
E [system.fi@hydro.com](mailto:system.fi@hydro.com)

### Lithuania/Estonia/Latvia

LT-02244 Vilnius  
T +370 (0)5 210 25 87  
E [sapa.lt@hydro.com](mailto:sapa.lt@hydro.com)

### Poland

92-620 Łódź, Polska  
T +48 (0)42 683 63 73  
E [sapa.pl@hydro.com](mailto:sapa.pl@hydro.com)

[sapabuildingsystem.com](http://sapabuildingsystem.com)